

# **VorTek Series U44 Ultrasonic Flow Meter**

## **Instruction Manual**

M-000-00090

Rev 8/2021



8475 W I-25 Frontage Rd  
Suite 300  
Longmont, CO 80504  
(303) 682-9999 (888) 386-7835 Fax (303) 682-4368  
<http://www.vortekinst.com>

# Notice

Thank you for choosing our Ultrasonic Flow Meter.

Please read the instruction manual carefully before you use the flow meter to avoid damaging the flow meter or improper use.



**Warning**

May cause injury.

---



**Attention**

May damage the flow meter.

---

Some of the instructions may be different for the flow meter you purchased, depending on the configuration requirements. Otherwise, there is no indication about the product design and upgrade requirements in the instructions. Please refer to the version number as well as the Appendices.

# Product Components

Be sure to inspect all product components before installing the flow meter. Check to see if the spare parts are in accordance with the packing list. Make sure that there is no damage to the enclosure due to a loose screw or wire or other damage that may have occurred during transportation. If you have any questions, please contact your representative immediately.

## Accessories

1. Carrying Case
2. Handheld Transmitter
3. Transducers (Pair)
4. Transducer Mounting Bracket
5. Transducer Mounting Bracket Pipe Straps (Pair)
6. Acoustic Coupling Grease
7. Battery Charger
8. Output Cable
9. Measuring Tape



# Table of Contents

1.	Product Overview .....	7
1.1	Introduction .....	7
1.2	Features of the Ultrasonic Flow Meter .....	7
1.3	Theory of Operation .....	7
1.4	Applications.....	8
1.5	U44 Specifications.....	8
2.	Installation .....	10
2.1	Wire Connections .....	10
2.1.1	U44 Connections .....	10
2.1.2	Breakout Box Connections .....	10
2.2	Powering On.....	11
2.3	Clamp-On Transducer Installation .....	11
2.3.1	Measurement Site Selection .....	11
2.3.2	Transducer Spacing .....	12
2.3.3	Transducer Mounting Method .....	12
2.3.4	V Method.....	13
2.3.5	W Method.....	14
2.3.6	Z Method .....	15
2.4	Insertion Transducer Installation .....	15
2.4.1	Measurement Site Selection .....	16
2.4.2	Transducer Mounting Instructions.....	17
2.4.3	V Method.....	18
2.4.4	Z Method .....	18
2.5	Transducer Mounting Inspection.....	18
2.5.1	Signal Strength .....	18
2.5.2	Signal Quality (Q Value).....	19
2.5.3	Total Time and Delta Time.....	19
2.5.4	Transit Time Ratio.....	19
2.5.5	Warnings.....	19
3.	Display & Menus.....	21
3.1	Display & Keypad .....	21
3.1.1	Keypad Functions .....	21
3.1.2	Keypad Operation.....	21

3.2	Using the Setup Menus.....	22
3.2.1	Programming the Flow Meter.....	23
3.2.2	Output Menu.....	23
3.2.3	Display Menu .....	24
3.2.4	Totalizer #1 Menu .....	24
3.2.5	Totalizer #2 Menu .....	25
3.2.6	Energy Menu .....	25
3.2.7	Fluid Menu .....	26
3.2.8	Units Menu .....	26
3.2.9	Time & Date Menu.....	27
3.2.10	Diagnostics Menu .....	27
3.2.11	Calibration Menu.....	28
3.2.12	Password Menu.....	28
3.2.13	Engineer Menu .....	29
3.2.14	Engineer Menu 2 .....	30
4.	Operation Instructions .....	31
4.1	System Normal Identification.....	31
4.2	Low Velocity Cutoff Value .....	31
4.3	Zero Point Settings .....	31
4.4	Scale Factor .....	31
4.5	System Lock .....	32
4.6	Active 4 - 20 mA Current Loop Output.....	32
4.7	Frequency Output .....	32
4.8	Totalizer Pulse Output .....	33
4.9	Active 4 - 20 mA Analog Output Calibration .....	33
4.10	SD Card Operation .....	34
4.10.1	Specifications.....	34
4.10.2	Install or Remove the SD Card While the Meter is Powered On .....	34
4.11	Serial Number.....	34
5.	Troubleshooting.....	35
6.	Appendix 1 – Serial Interface Network Use and Communications Protocol .....	38
6.1	Overview .....	38
6.2	Connection via RS-485 to the Host Device.....	38
6.3	Modbus Communications Protocol and Use .....	38

6.3.1	HL Protocol .....	38
6.3.2	Modbus Protocol.....	40
7.	Appendix 2 – Flow Application Data.....	45
7.1	Sound Velocity and Viscosity for Fluids Commonly Used.....	45
7.2	Sound Velocity for Various Materials Commonly Used.....	45
7.3	Sound Velocity in Water (1 atm) at Different Temperatures .....	46

# 1. Product Overview

## 1.1 Introduction

This product is a portable, clamp-on type ultrasonic flow meter using transfer time technology. The clamp-on type ultrasonic flow meter is easy to attach and has no need to cut off the pipe, which saves you a lot of trouble and cost. At the same time, this flow meter has our unique calculation software to ensure high accuracy and low velocity response.

This ultrasonic flow meter is applicable to the oil industry, water treatment, pure water, chemical, etc.

The ultrasonic flow meter could add an RTD model and temperature sensor to become an energy meter for the monitoring of energy use.

## 1.2 Features of the Ultrasonic Flow Meter

When comparing this flow meter with other traditional flow meters or ultrasonic flow meters, it has distinctive features including high precision, high reliability, high capability, and low cost. The flow meter features other advantages:

1. With ARM chip, low power consumption, high reliability, anti-jamming, and outstanding benefits.
2. User-friendly menu design. Parameters of pipe range, pipe material, pipe wall thickness, output signals, etc. can be conveniently entered via the menus. US and Metric measurement units are available.
3. Daily, monthly, and yearly totalized flow: totalized flow for the last 64 days and months as well as for the last 6 years may be viewed. With the SD Card, 512 files can be stored; the time interval can be within 1 second.
4. Parallel operation of positive, negative, and net flow totalizer with scale factor and 7-digit display. An internally configured batch controller makes batch control convenient.

The flow meter ensures a higher resolution and wider measuring range by the 0.04 ns high resolution, high linearity, and high stability time measuring circuit and 32 bits digits processing program.

## 1.3 Theory of Operation

When the ultrasonic signal is transmitted through the flowing liquid, there will be a difference between the upstream and downstream transit time (travel time or time of flight), which is proportional to flow velocity, according to the formula below:

$$V = \frac{MD}{\sin 2\theta} \times \frac{\Delta T}{T_{up} \cdot T_{down}}$$

Remarks:

- $V$  Medium velocity  
 $M$  Ultrasonic frequency of reflection  
 $D$  Pipe diameter  
 $\theta$  Angle between the ultrasonic signal and the flow  
 $T_{up}$  Transit time in the forward direction  
 $T_{down}$  Transit time in the reverse direction  
 $\Delta T = T_{up} - T_{down}$

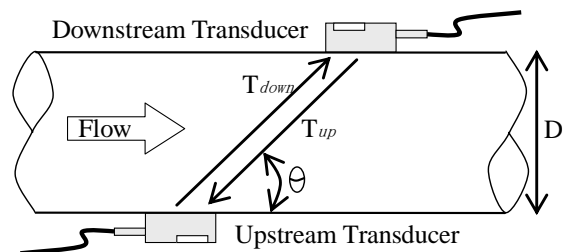

## 1.4 Applications

- Water, sewage (with low particle content), and seawater;
- Water supply and drainage water;
- Power plants (nuclear power plant, thermal, and hydropower plants), heat energy, boiler feed water, and energy management system;
- Metallurgy and mining applications (cooling water and acid recovery, for example);
- Petroleum and chemicals;
- Food, beverage, and pharmaceutical;
- Marine operation and maintenance;
- Energy economy supervision and water conservation management;
- Pulp and paper;
- Pipeline leak detection;
- Regular inspection, tracking, and collection;
- Energy measuring and balance;
- Network monitoring systems and energy / flow computer management.

## 1.5 U44 Specifications

<b>Performance Specifications</b>	
Flow Range	± 40 ft/s (± 12 m/s).
Accuracy	± 1% of reading
Repeatability	0.2% of reading
Pipe Size	1" ~ 48" (25 mm ~ 1200 mm).
<b>Function Specifications</b>	
Output	Analog output: 4 ~ 20 mA, (max load 750 Ω); Pulse output: 0 ~ 9999 Hz, Open Collector Transistor (OCT) (min. and max. frequency is adjustable);
Communication Interface	RS-485 Modbus
SD Card (standard)	Max record: 512 days. Record time interval: 1 ~ 3600 s.
Power Supply	Rechargeable Lithium Battery Power, 3000mAh (16 hour batter life under continuous operation)
Keypad	16 light tactile keys.
Display	240*128 lattice, backlit LCD.



Transmitter Temperature	Transmitter: -40 °F ~ 140 °F (- 40 °C ~ 60 °C).
Humidity	Up to 99% RH, non-condensing.
<b>Physical Specifications</b>	
Transmitter	NEMA13, IP54
Transducer	Encapsulated design, IP68 Standard / Maximum cable length: 16ft (5m)

## 2. Installation

### 2.1 Wire Connections

#### 2.1.1 U44 Connections

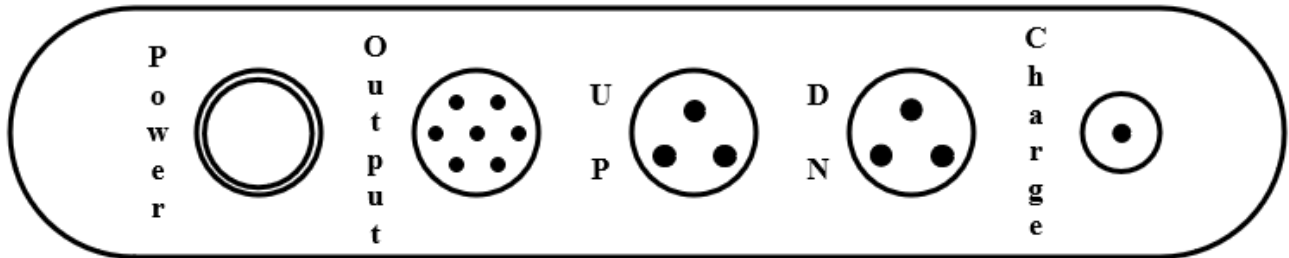

#### 2.1.2 Breakout Box Connections

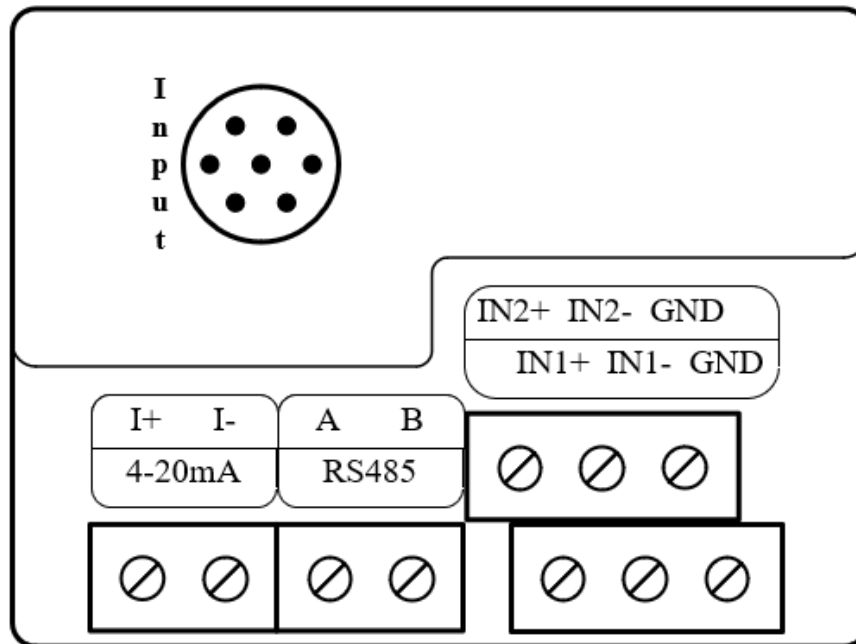

Refer to the below diagram for specific connection:

Sign	Description
I +	4 - 20 mA
I -	
A	RS-485 Output
B	
IN2+	Temperature Sensor Outline +
IN2-	Temperature Sensor Outline -
GND	Temperature Sensor Outline Grounding

IN1+	Temperature Sensor Inline +
IN1-	Temperature Sensor Inline -
GND	Temperature Sensor Inline Grounding

## 2.2 Powering On

As soon as the flow meter is switched on, the system will run automatically according to the last input parameters. After installation, when the system is switched on, gain adjustment can be monitored in the Run Mode Screens. After code "\*R" is displayed on the upper right corner of the screen, the system will activate the normal measurement condition automatically. It is indicated by code "\*R" on the upper right corner of the screen.

If it is the first use or install on a new site, the customer needs to input the new installation site parameters. Any parameters which are set by the user will be saved permanently until they are changed by the user.

When the user modifies the parameters and removes the transducers, the meter will recalculate automatically, and operate normally with the parameters.

The flow meter can always complete all tasks at the same time. The tasks (including measurement, output, etc.) will be carried out as usual, no matter which screen is displayed.

## 2.3 Clamp-On Transducer Installation

Please make sure the pipe surface where the transducers are to be mounted is clean. Ensure the removal of rust, scale, or loose paint to have a smooth surface. Choose the section and apply the coupling compound down the center of the face of each transducer as well as on the pipe surface. Ensure there are no air bubbles between the transducers and the pipe wall. Attach the transducers to the pipe with the straps provided and tighten them securely.

**Note:** The two transducers should be mounted at the pipe's centerline on horizontal pipes.

Make sure that the transducer mounting direction is parallel with the flow.

During the installation, there should be no air bubbles or particles between the transducer and the pipe wall. On horizontal pipes, the transducers should be mounted in the 3 o'clock and 9 o'clock positions of the pipe section in order to avoid any air bubbles inside the top portion of the pipe. (Refer to Measurement Site Selection). If the transducers cannot be mounted horizontally symmetrically due to limitation of the local installation conditions, it may be necessary to mount the transducers at a location where there is a guaranteed full pipe condition (the pipe is always full of liquid).

### 2.3.1 Measurement Site Selection

The installation of the clamp-on transducers is the simplest of all kinds of flow meters. Only one suitable measuring site is needed. Attach the transducers to the pipe and start the measurement.

When selecting a measurement site, it is important to select an area where the fluid flow profile is fully developed to guarantee a highly accurate measurement. Use the following guidelines to select a proper installation site:

- Choose a section of pipe that is always full of liquid, such as a vertical pipe with flow in the upward direction or a full horizontal pipe.
- Ensure enough straight pipe length at least equal to the figure shown below for the upstream and downstream transducers installation.

Conditions	Upstream Straight Run	Downstream Straight Run
General Conditions	10D	5D
Elbow	10D	5D
Partially Open Valve	30D	10D
Reduced Pipe	10D	5D
Expanded Pipe	30D	5D

- On the horizontal pipe, the transducer should be mounted on the 9 o'clock and 3 o'clock positions of the pipe, avoiding the positions of 6 o'clock and 12 o'clock, in case of signal attenuation caused by the pipe, sediment at the bottom, or bubble cavitation on the pipe.

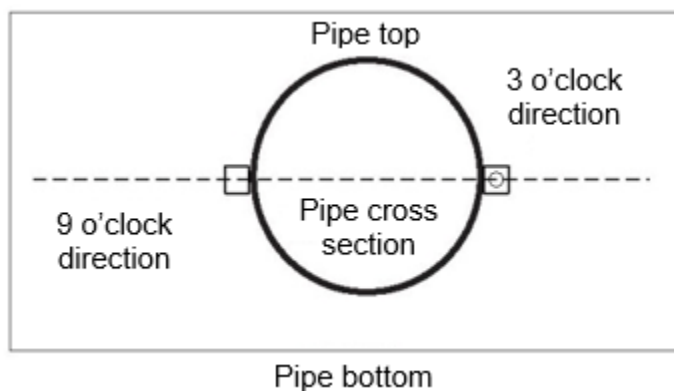

- Ensure that the measuring site temperature is under the transducer temperature limits.
- Consider the inside condition of the pipe carefully. If possible, select a section of pipe where the inside is free of excessive corrosion or scaling.
- Choose a section of sound conducting pipe.
- Avoid installation on pipes with mechanical vibrations. If impossible, take shock absorption measures.

### 2.3.2 Transducer Spacing

The spacing between the ENDS of the two transducers is considered as the standard transducer spacing. After entering the required parameters, check the data displayed in the Calibration Menu and adjust the transducer spacing according to the data displayed in the Calibration Menu.

### 2.3.3 Transducer Mounting Method

There are three mounting method that can be used depending on the measuring environment: V method (reflect method), W method, and Z method (direct method).

V method is easy to install and is fit for most ultrasonic environments, but Z method has a stronger signal and works better in a complicated measuring environment. W method can have a stronger signal than V method for smaller pipe diameters.

### 2.3.4 V Method

The V method is considered the standard method. It is convenient to use, but still requires proper installation of the transducers, contact on the pipe at the centerline, and equal spacing on either side of the centerline. This is recommended for carbon steel pipes.

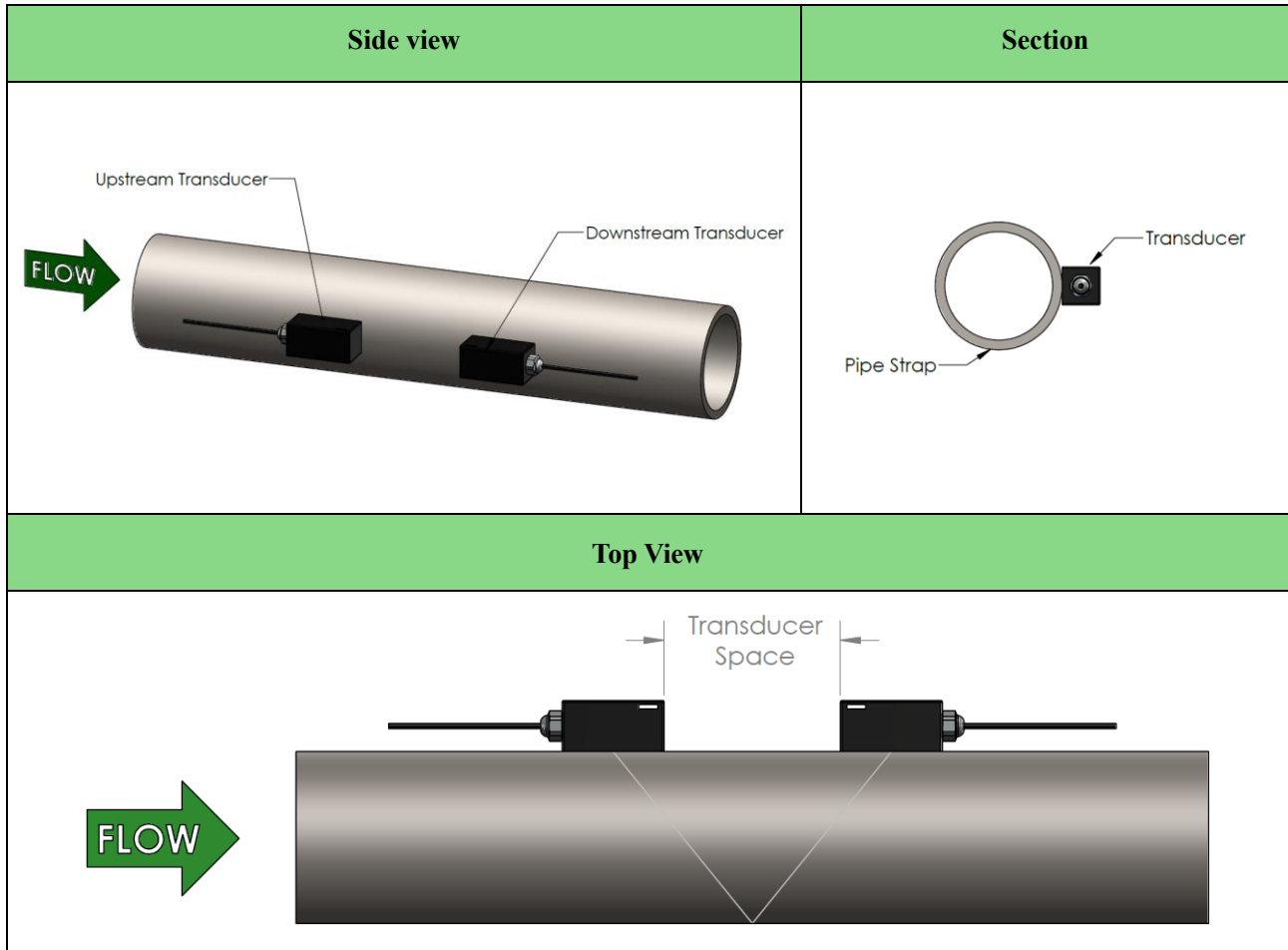

### 2.3.5 W Method

The signal transmitted in a W method may be stronger than with the V method on smaller diameter pipes. This method is recommended for pipes with diameters of 3 inches (75 mm) and below or PVC pipes.

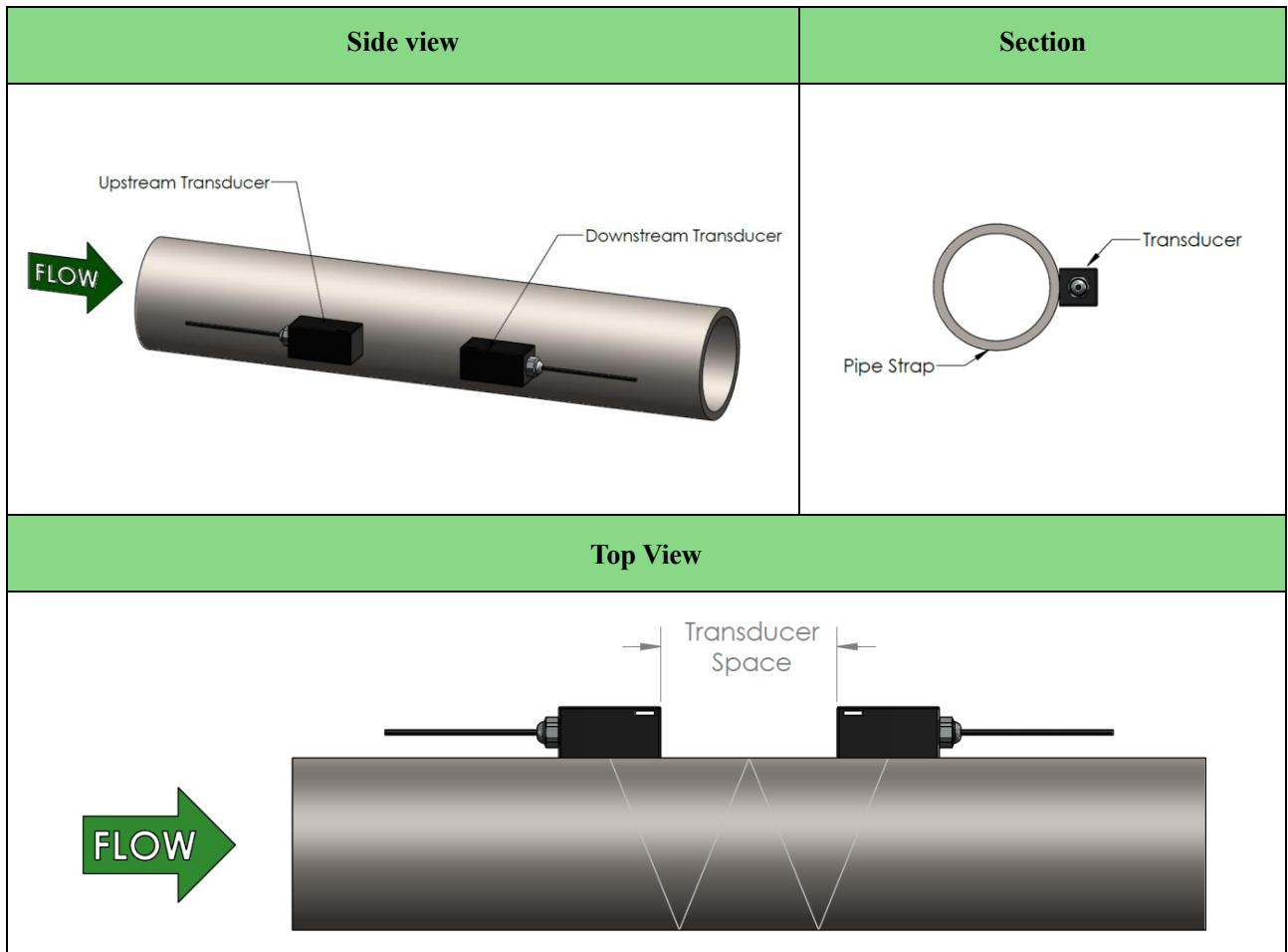

### 2.3.6 Z Method

The signal transmitted in a Z method installation has less attenuation than a signal transmitted with the V or W methods. When pipes are too large, there is some suspended solid in the fluid or the scaling and liner are too thick. This is why the Z method utilizes a directly transmitted (rather than reflected) signaling which transverses the liquid only once. The Z method is able to measure on pipe diameters ranging from 4 to 48 inches (100 mm to 1200 mm) approximately. Therefore, the Z method is recommended for pipe diameters over 12 inches (300 mm).

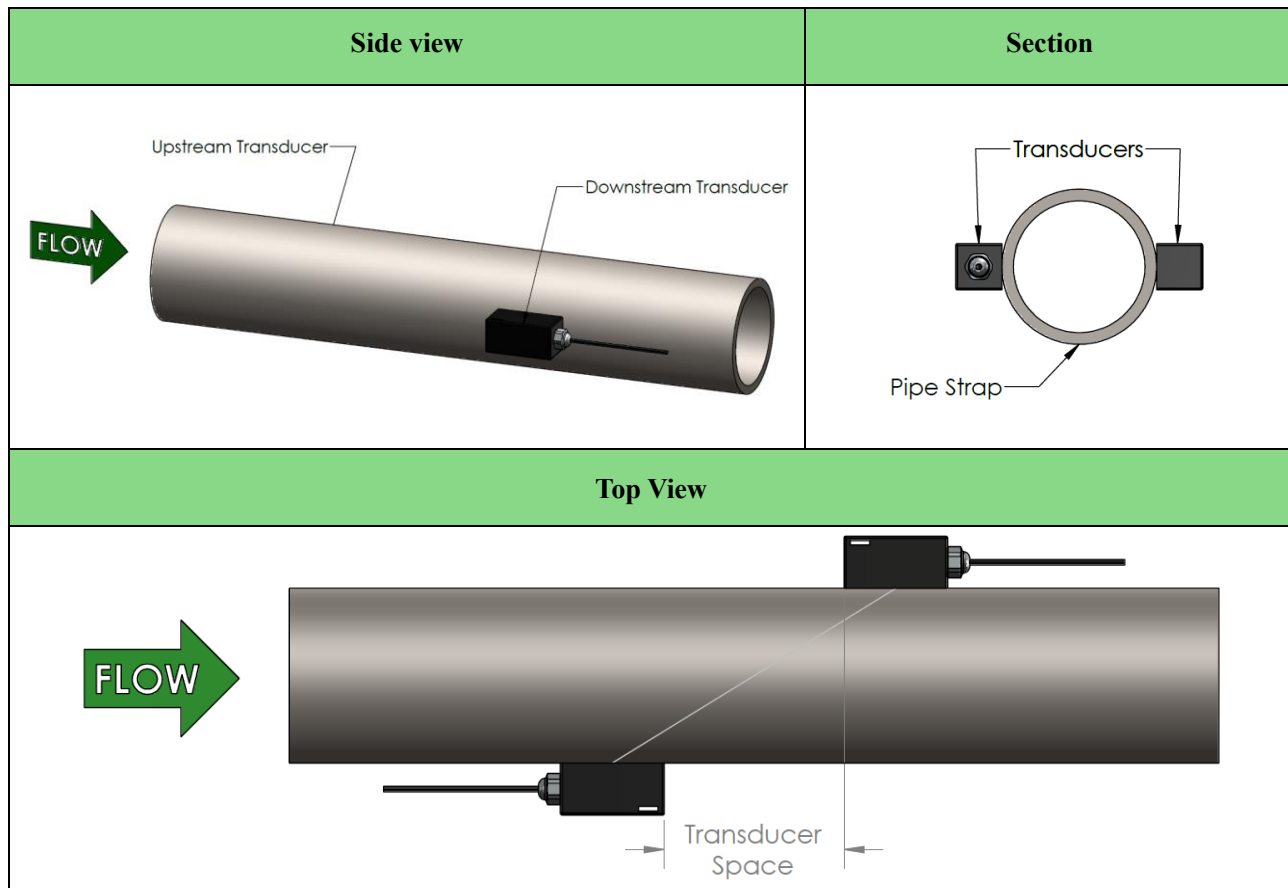

### 2.4 Insertion Transducer Installation

The W1 type insertion transducers can be installed into metal pipelines via an isolation ball valve (installation into pipelines of plastic or other materials may require an optional mounting seat). The maximum pipe diameter in which insertion transducers can be installed is DN1200. The fluid temperature range of these transducers is  $-40^{\circ}\text{C} \sim 130^{\circ}\text{C}$ . The sensor cable length (5m standard) can be extended to as long as 30m.

The below figure shows a diagram of the W1 Insertion Transducer. The transducer is attached to its mounting base (which is welded to the pipe section at the measurement point) via a ball valve. An O-ring seal is used to seal the probe and to allow for installation or extraction under flowing conditions.

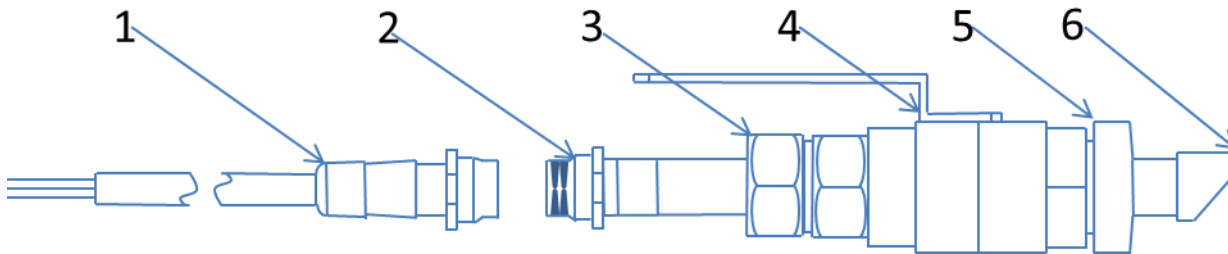

1. Cable    2. Connector    3. Lock-nut    4. Ball valve    5. Mounting Base    6. Transducer probe

### 2.4.1 Measurement Site Selection

When selecting a measurement site, it is important to select an area where the fluid flow profile is fully developed to guarantee a highly accurate measurement. Use the following guidelines to select a proper installation site:

- Choose a section of pipe that is always full of liquid, such as a vertical pipe with flow in the upward direction or a full horizontal pipe.
- Ensure enough straight pipe length at least equal to the figure shown below for the upstream and downstream transducers installation.

Conditions	Upstream Straight Run	Downstream Straight Run
General Conditions	10D	5D
Elbow	10D	5D
Partially Open Valve	30D	10D
Reduced Pipe	10D	5D
Expanded Pipe	30D	5D

- On the horizontal pipe, the transducer should be mounted on the 9 o'clock and 3 o'clock positions of the pipe, avoiding the positions of 6 o'clock and 12 o'clock, in case of signal attenuation caused by the pipe, sediment at the bottom, or bubble cavitation on the pipe.

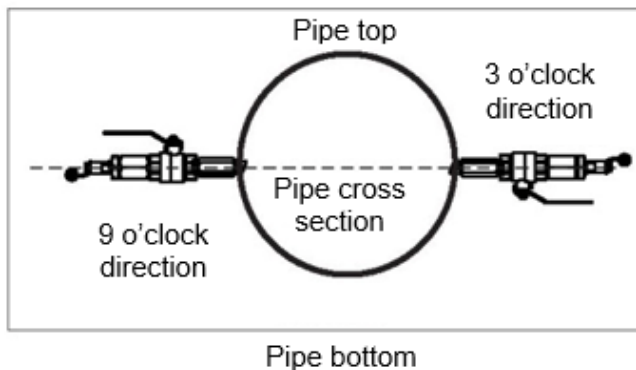

- Ensure that the measuring site temperature is under the transducer temperature limits.
- Consider the inside condition of the pipe carefully. If possible, select a section of pipe where the inside is free of excessive corrosion or scaling.



### 2.4.2 Transducer Mounting Instructions

1. Drill a 24mm diameter hole at the measuring point. Be sure to center of the hole is aligned to match the location for the center of the transducer. Weld the coupling adapter in place.
2. Close the ball valve and screw it tightly on the mounting base.
3. Twist off the lock-nut and loosen the locking ring. Pull the transducer into the joint nut and screw the joint nut onto the ball valve.
4. Open the ball valve and insert the transducer. Measure the dimension from the outer surface of the pipe to the front-end surface of the handspike position to meet the following formula:

$$H = 216 - d_1 - d_2$$

H = mounting height (mm)     $d_1$  = pipe wall thickness (mm)     $d_2$  = pipe liner thickness (mm)

If there is no liner,  $d_2 = 0$

5. Attach the lock ring to the joint nut by fitting its pinhole in the locating pin. Tighten the screw slightly and turn the orientation handle until it points at the middle position between the two transducers and its axes match the axes of the pipeline. Finally, tighten the locking screw and screw the locating sleeve onto the joint nut.
6. Connect the transducer cables to the corresponding upstream/downstream (upstream = red, downstream = blue) terminal ends
7. Please refer to the following installation diagram

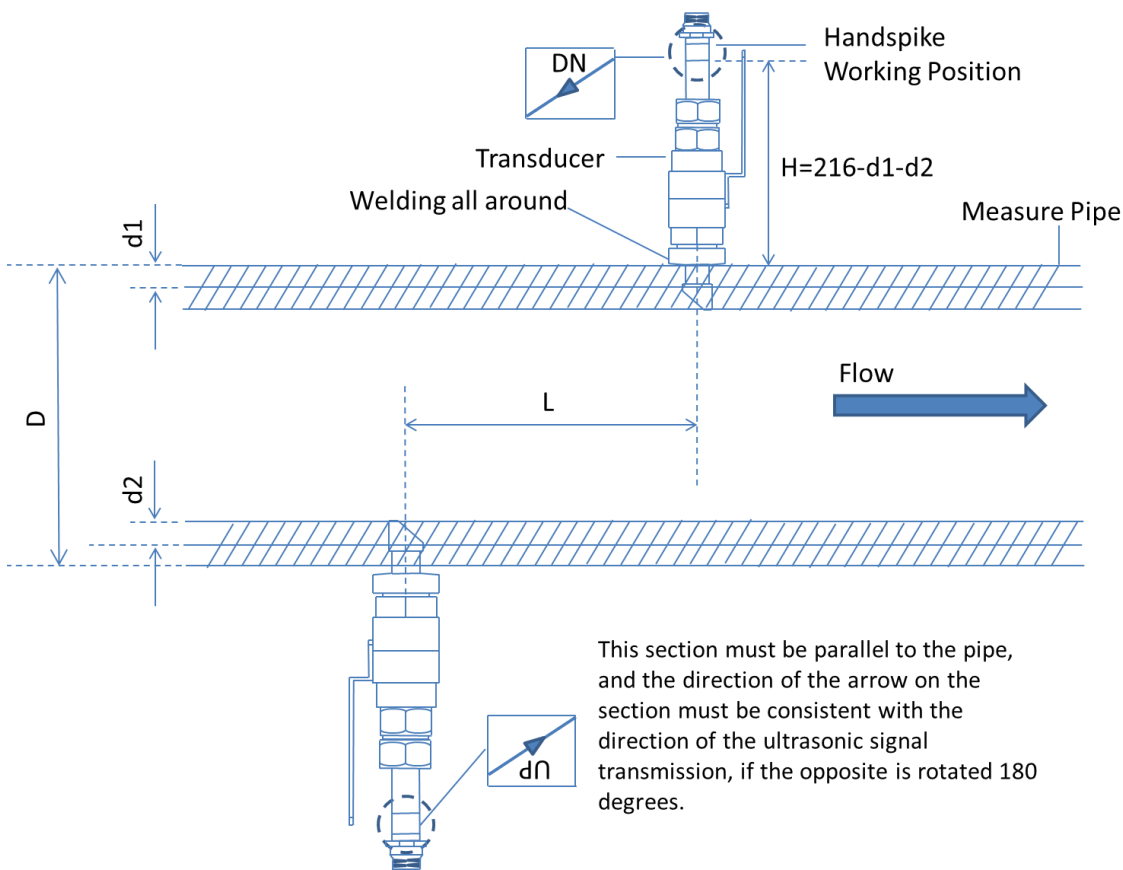

### 2.4.3 V Method

The V method is considered as the standard method. It is convenient to use, but still requires proper installation of the transducers, contact on the pipe at the pipe’s centerline, and equal spacing on either side of the centerline.

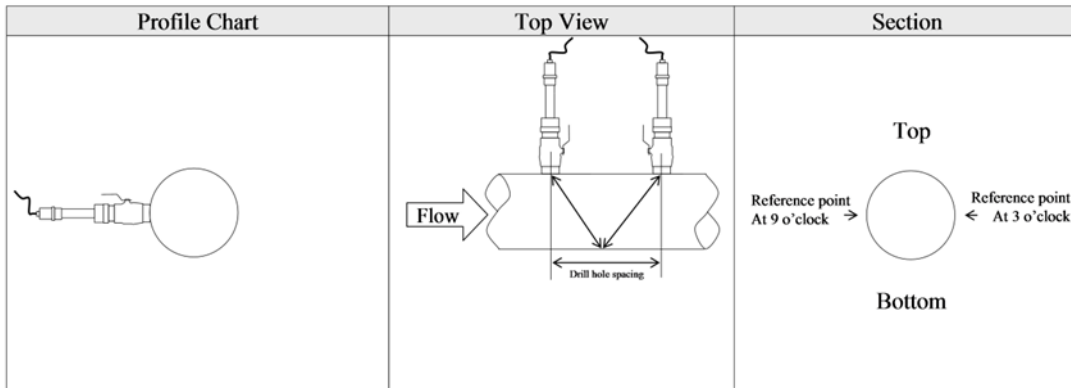

### 2.4.4 Z Method

The signal transmitted in a Z method installation has less attenuation than a signal transmitted with the V method.

When the pipes are too large, there are some suspended solids in the fluid or the scaling and liner are too thick. The Z method utilizes a directly transmitted (rather than reflected) signaling which transverses the liquid only once. The Z method is able to measure on pipe diameters ranging from 100mm to 1200mm (4 inch to 48 inch) approximately. Therefore, we recommend the Z method for pipe diameters over 300mm (12 inch).

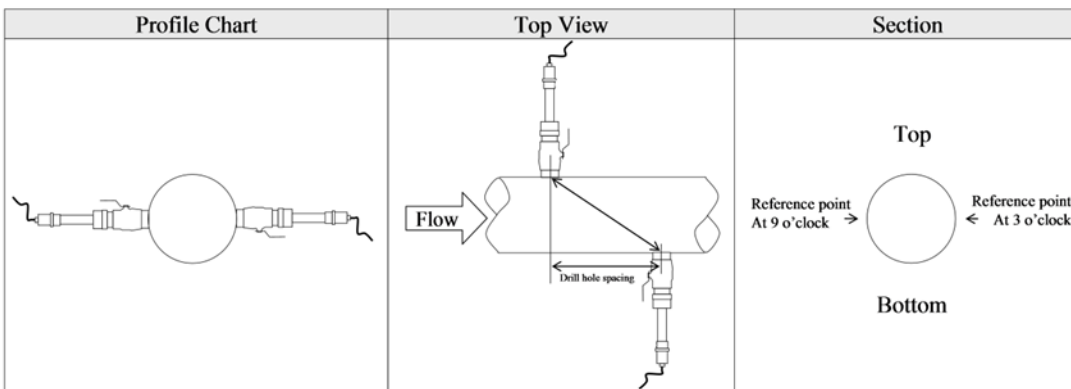

## 2.5 Transducer Mounting Inspection

### 2.5.1 Signal Strength

Signal strength (displayed in the Diagnostics Menu) indicates a detected strength of the signal both from upstream and downstream directions. The relevant signal strength is indicated by numbers from 00.0 ~ 99.9. The 00.0 value represents no signal detected while 99.9 represent maximum signal strength. Normally, the stronger the signal strength detected, the longer the operation of the instrument is reliable, as well as the more stable the obtained measurement value.

Adjust the transducer to the best position and check to ensure that enough sonic coupling compound was applied during installation to obtain the maximum signal strength.

The system normally requires a signal strength over 75.0, which is detected from both upstream and downstream directions. If the signal strength detected is too low, the transducer installation position and the transducer mounting spacing should be readjusted and the pipe should be reinspected. If necessary, change the mounting method to the Z method.

### 2.5.2 Signal Quality (Q Value)

Q value is short for Signal Quality (displayed in the Diagnostics Menu). It indicates the level of the signal detected. Q value is indicated by numbers from 00 ~ 99. The 00 value represents the minimum signal detected while 99 represent the maximum. Normally, the transducer position should be adjusted repeatedly and coupling compound application should be checked frequently until the signal quality detected is as strong as possible.

### 2.5.3 Total Time and Delta Time

"Total Time" and "Delta Time", which display in the Diagnostics Menu, indicate the condition of the installation. The measurement calculations in the flow meter are based upon these two parameters. Therefore, when "Delta Time" fluctuates widely, the flow and velocities fluctuate accordingly. This means that the signal quality detected is too poor. It may be the result of poor pipe installation conditions, inadequate transducer installation, or incorrect parameter input.

Generally, "Delta Time" fluctuation should be less than  $\pm 20\%$ . Only when the pipe diameter is too small, or velocity is too low can the fluctuation be wider.

### 2.5.4 Transit Time Ratio

Transit Time Ratio indicates if the transducer mounting spacing is accurate. The normal transit time ratio should be  $100 \pm 3$  if the transducers were installed properly. Check it in the Diagnostics Menu.

---

#### Attention

If the transit time ratio is over  $100 \pm 3\%$ , it is necessary to check:



- (1) If the parameters (pipe outside diameter, wall thickness, pipe material, liner, etc.) have been entered correctly,
  - (2) If the transducer mounting spacing is in accordance with the display in the Calibration Menu,
  - (3) If the transducer is mounted at the pipe's centerline on the same diameter,
  - (4) If the scale is too thick or the pipe mounting is distorted in shape, etc.
- 

### 2.5.5 Warnings

Pipe parameters entered must be accurate; otherwise the flow meter will not work properly.

During the installation, apply enough coupling compound to stick the transducers onto the pipe wall. While checking the signal strength and Q value, move the transducers slowly around the mounting site until the strongest signal and maximum Q value can be obtained. Make sure that the larger the pipe diameter, the more the transducers should be moved.

Check to be sure the mounting spacing is in accordance with the display in the Calibration Menu and the

transducer is mounted at the pipe's centerline on the same diameter.

Pay special attention to pipes formed by steel rolls (pipe with seams), since such pipe is always irregular. If the signal strength is always displayed as 0.00, that means there is no signal detected. Thus, it is necessary to check that the parameters (including all the pipe parameters) have been entered accurately. Check to be sure the transducer mounting method has been selected properly, the pipe is not worn-out, and the liner is not too thick. Make sure there is fluid in the pipe, the transducer is not too close to a valve or elbow, there are not too many air bubbles in the fluid, etc. If there is still no signal detected after checking these reasons, the measurement site needs to be changed.

Make sure that the flow meter is able to run properly with high reliability. The stronger the signal strength displayed, the higher the Q value reached. The longer the flow meter runs accurately, the higher the reliability of the flow rates displayed. If there is interference from ambient electromagnetic waves or the signal detected is too poor, the flow value displayed is not reliable; consequently, the capability for reliable operation is reduced.

After the installation is complete, power on the instrument and check the results accordingly.

# 3. Display & Menus

## 3.1 Display & Keypad

### 3.1.1 Keypad Functions

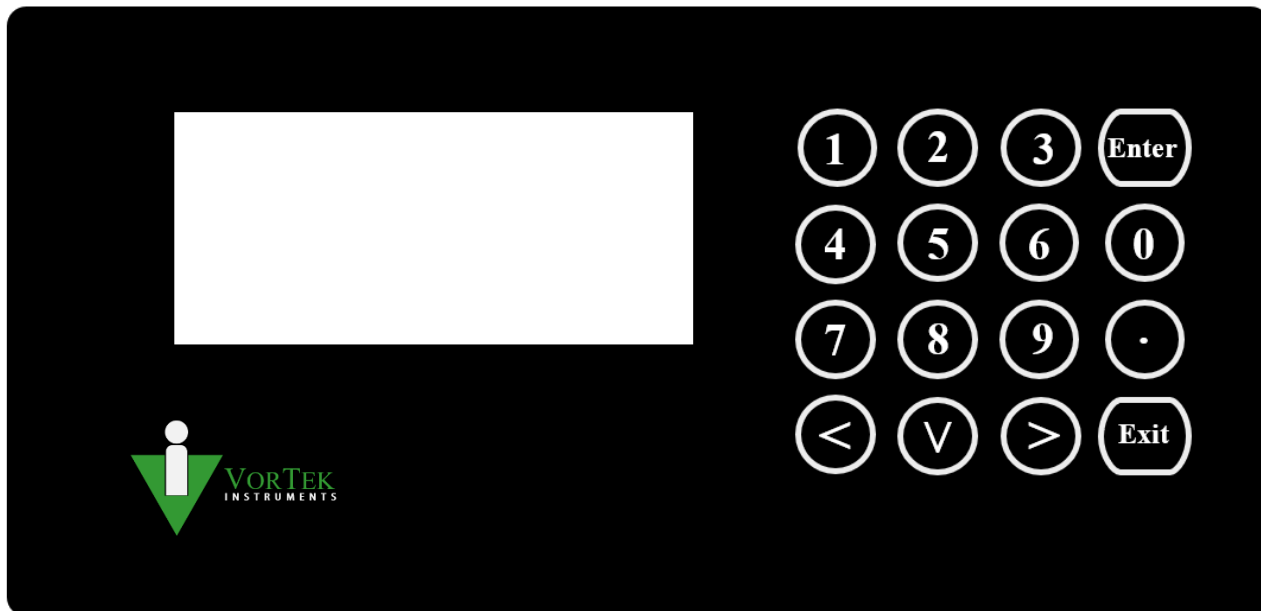

Numbers “0~9” and  input numbers or codes.





 goes back to the previous menu.

 opens the next menu.

 selects a menu or value.

### 3.1.2 Keypad Operation

The flow meter’s digital electronics allow you to set, adjust, and monitor system parameters and performance. A full range of commands are available through the display/keypad. The LCD display shows flow monitoring and programming. The multiple run screens are arranged in a loop that can be viewed after entering the password and

using the    buttons. If you want to modify the parameters, press  first, input the digits, then press  again to confirm.



#### Attention

Generally, press  key first if the operator wants to enter "modify" status. To unlock it, enter the password.

### 3.2 Using the Setup Menus

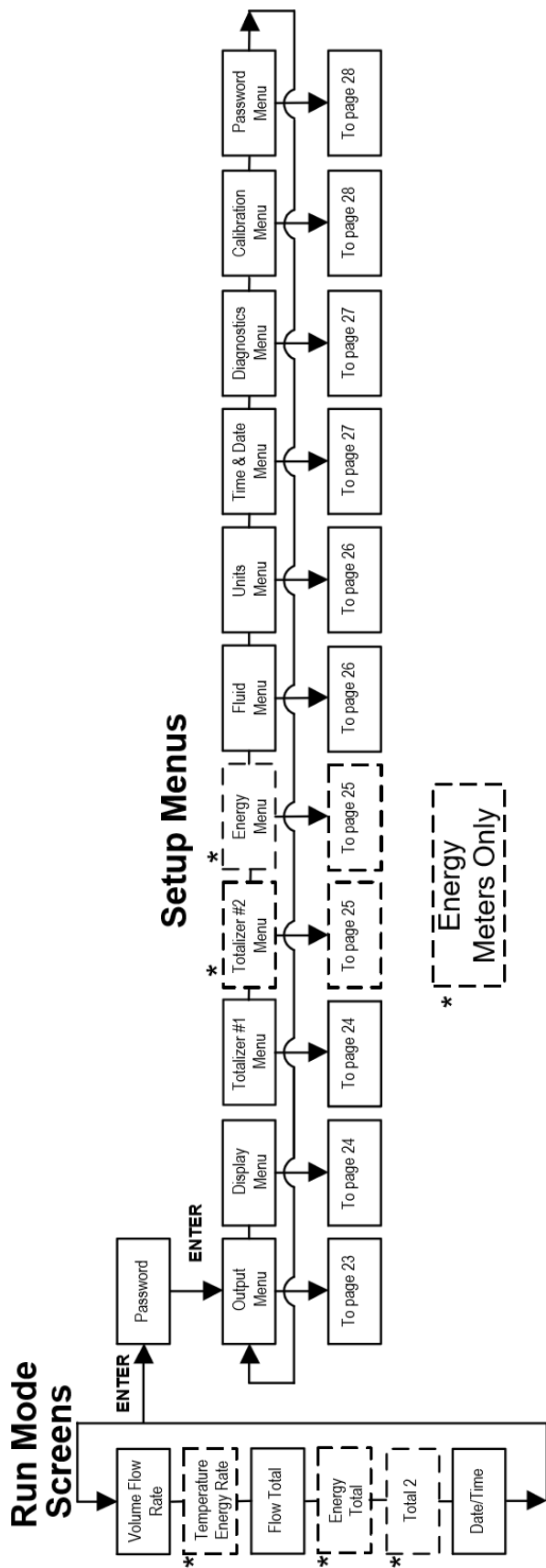

### 3.2.1 Programming the Flow Meter

1. Enter the Setup Menu by pressing the ENTER key until prompted for a password. (All outputs are disabled while using the Setup Menus.)
2. Use the number keys to enter the password (1234 is the factory-set password). When the password is correctly displayed, the Setup Menu will be displayed.
3. Use the Setup Menus described on the following pages to customize the multi-parameter features for your ultrasonic flow meter. Some items depicted in the graphic on the preceding page may not be displayed based on flow meter configuration and settings.
4. To activate a parameter, press ENTER. Use the < V > keys to make selections or enter using number keys. Press ENTER to continue. Press EXIT to save or discard changes and return to Run Mode.
5. **Program the UNITS menu first because later menus will be based on the units selected.**

### 3.2.2 Output Menu

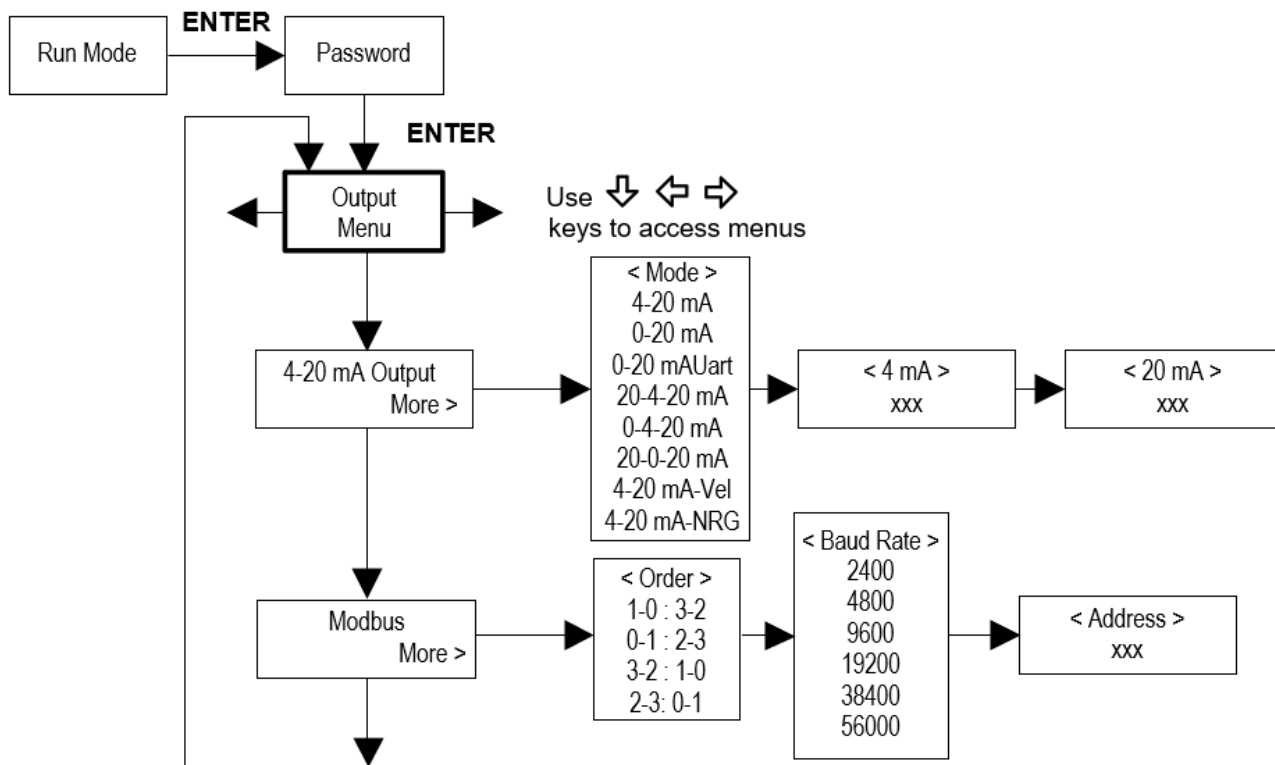

### 3.2.3 Display Menu

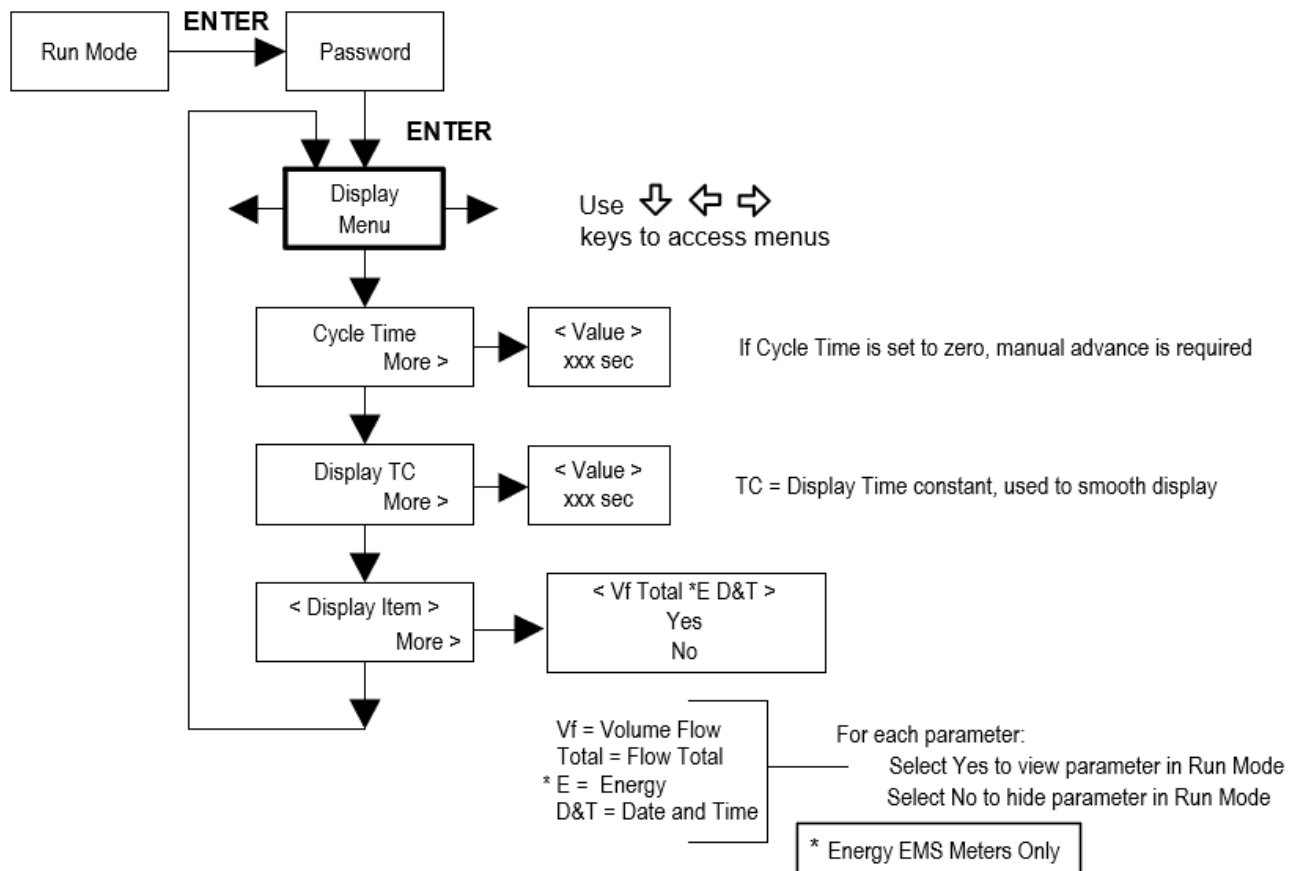

### 3.2.4 Totalizer #1 Menu

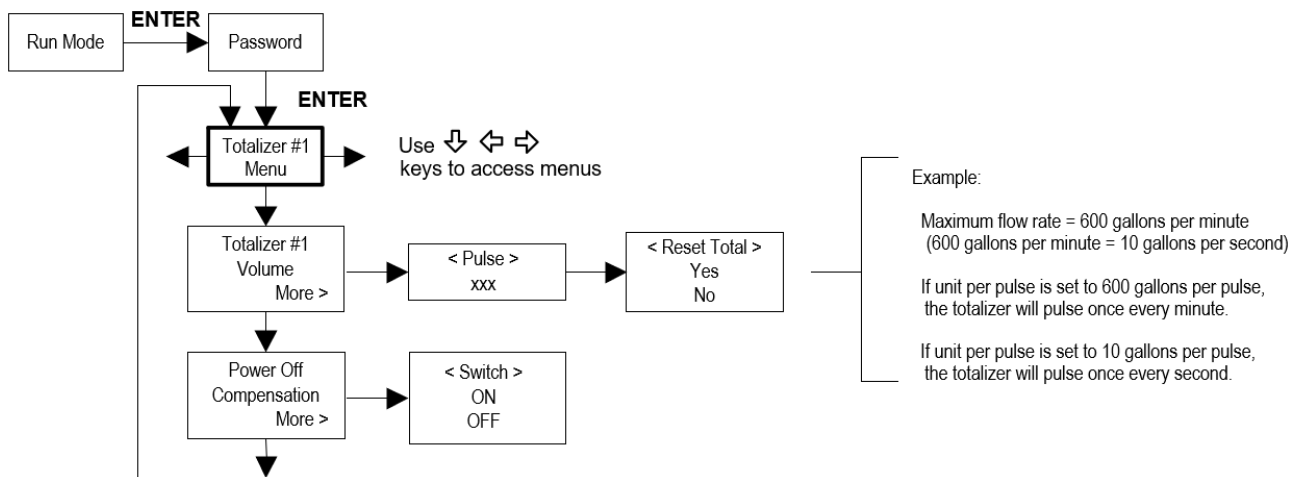



### 3.2.5 Totalizer #2 Menu

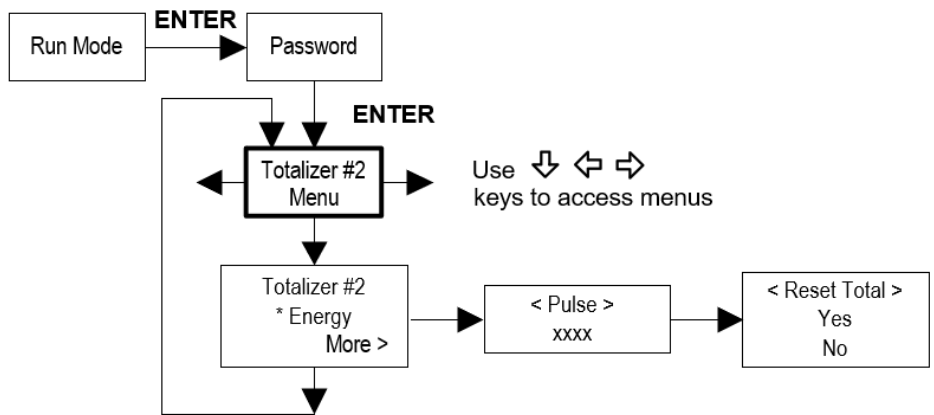

### 3.2.6 Energy Menu

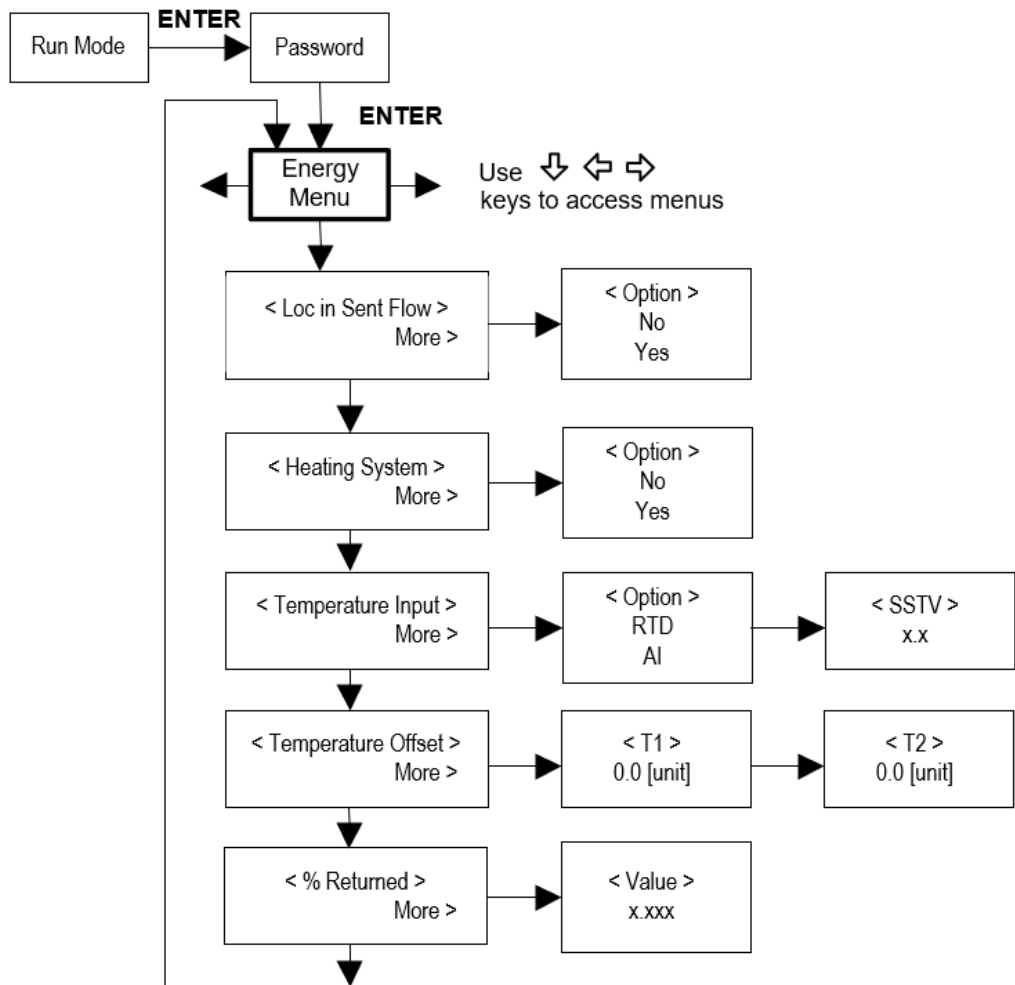

### 3.2.7 Fluid Menu

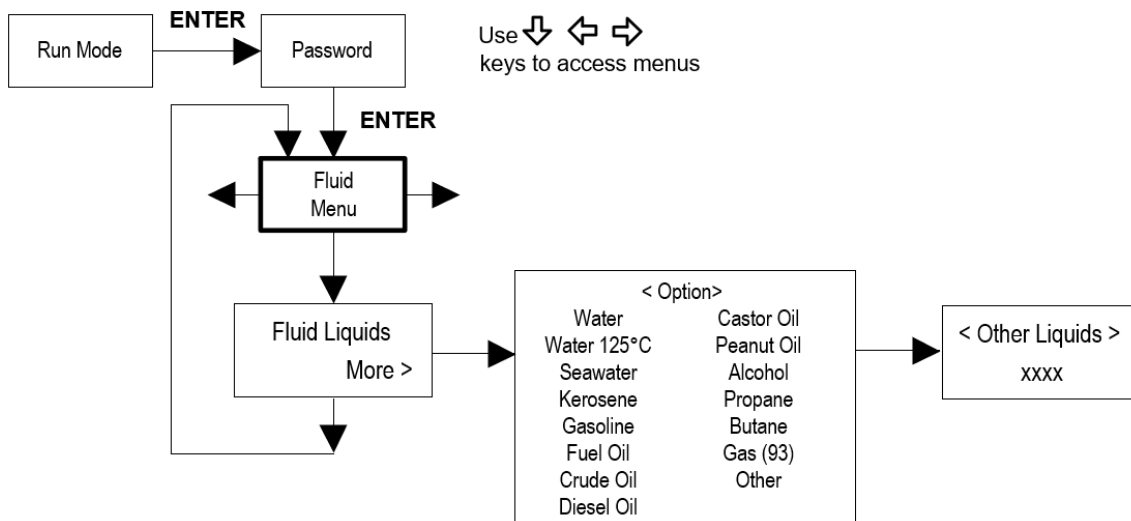

### 3.2.8 Units Menu

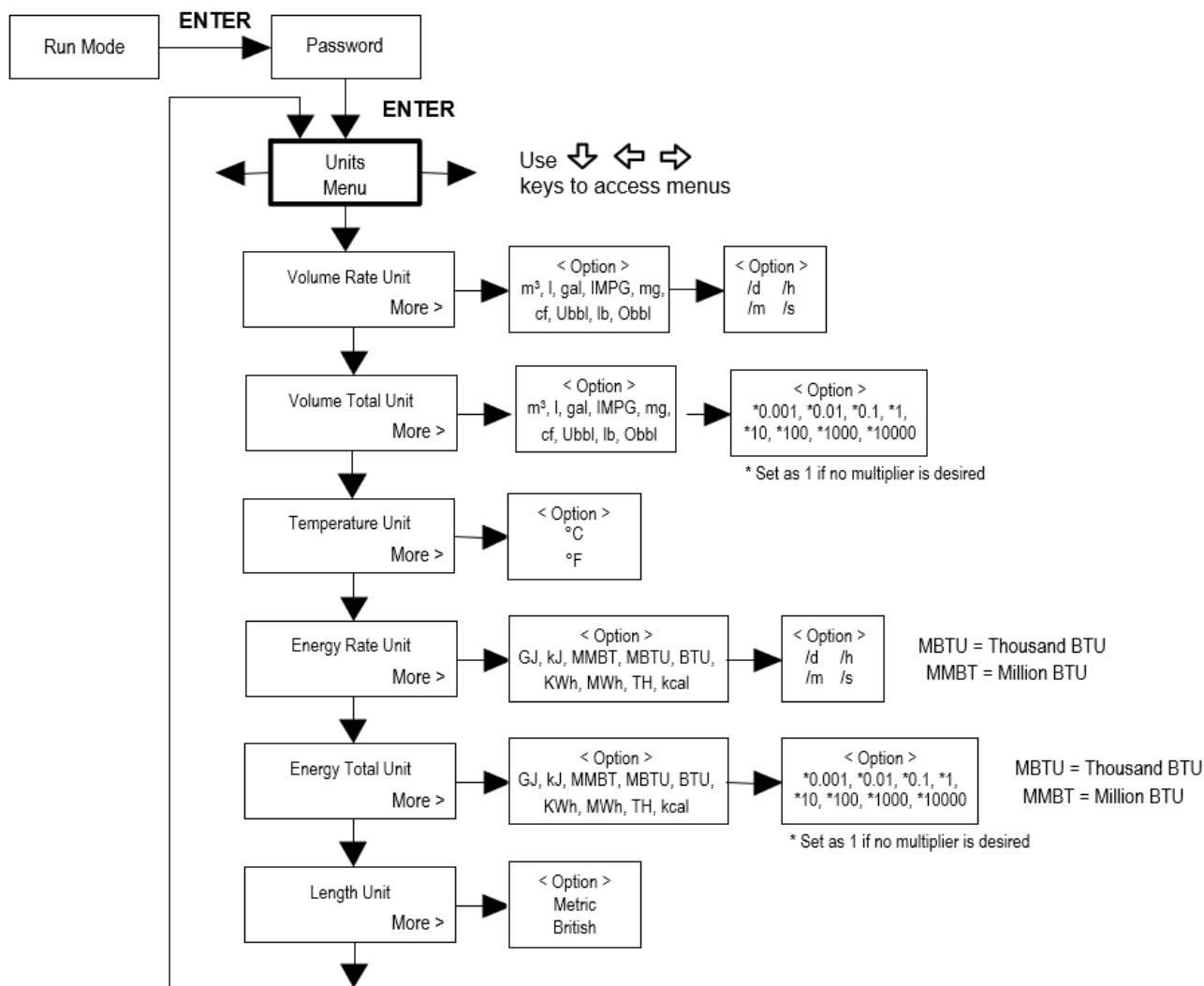

### 3.2.9 Time & Date Menu

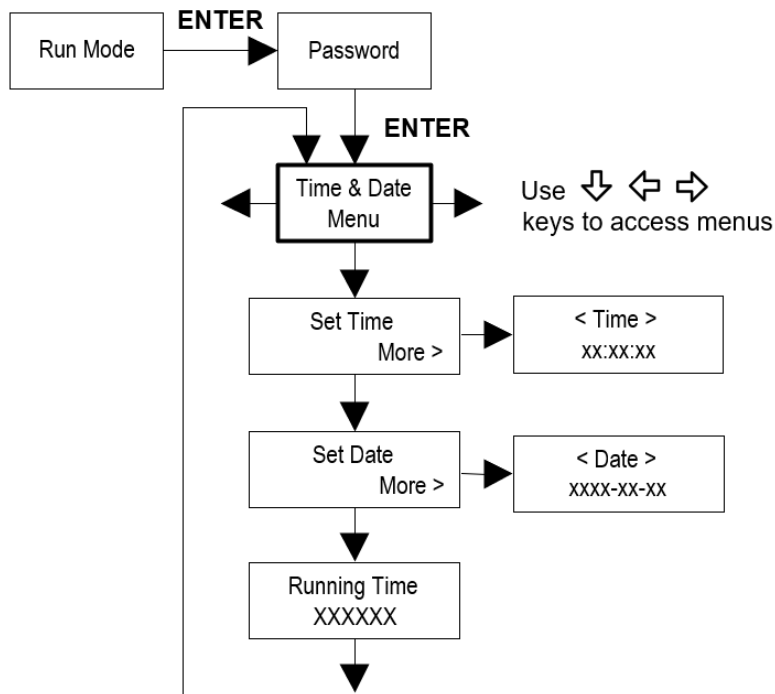

### 3.2.10 Diagnostics Menu

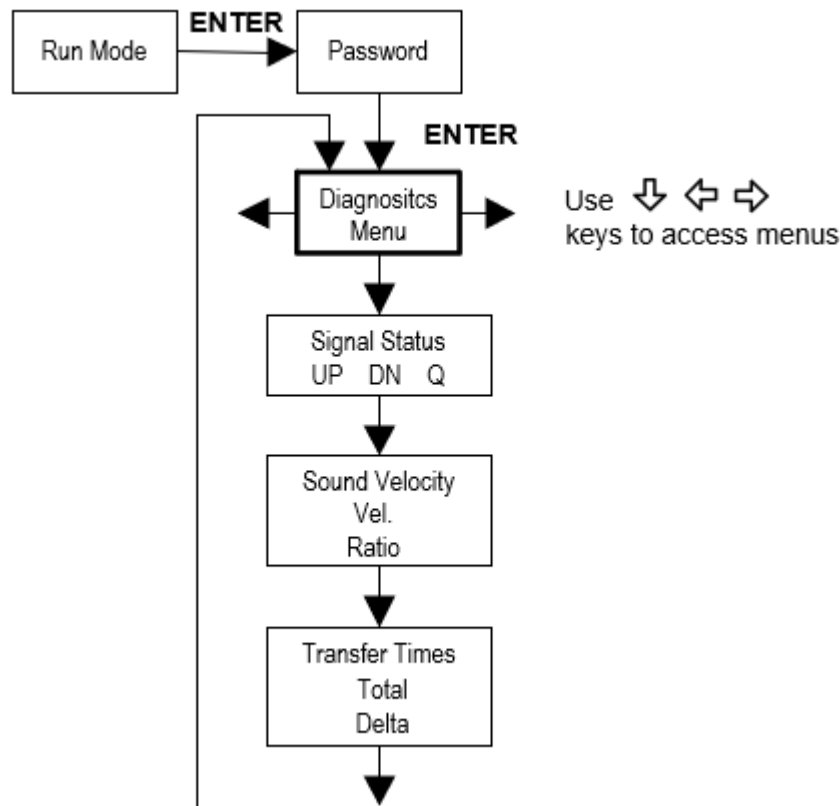

### 3.2.11 Calibration Menu

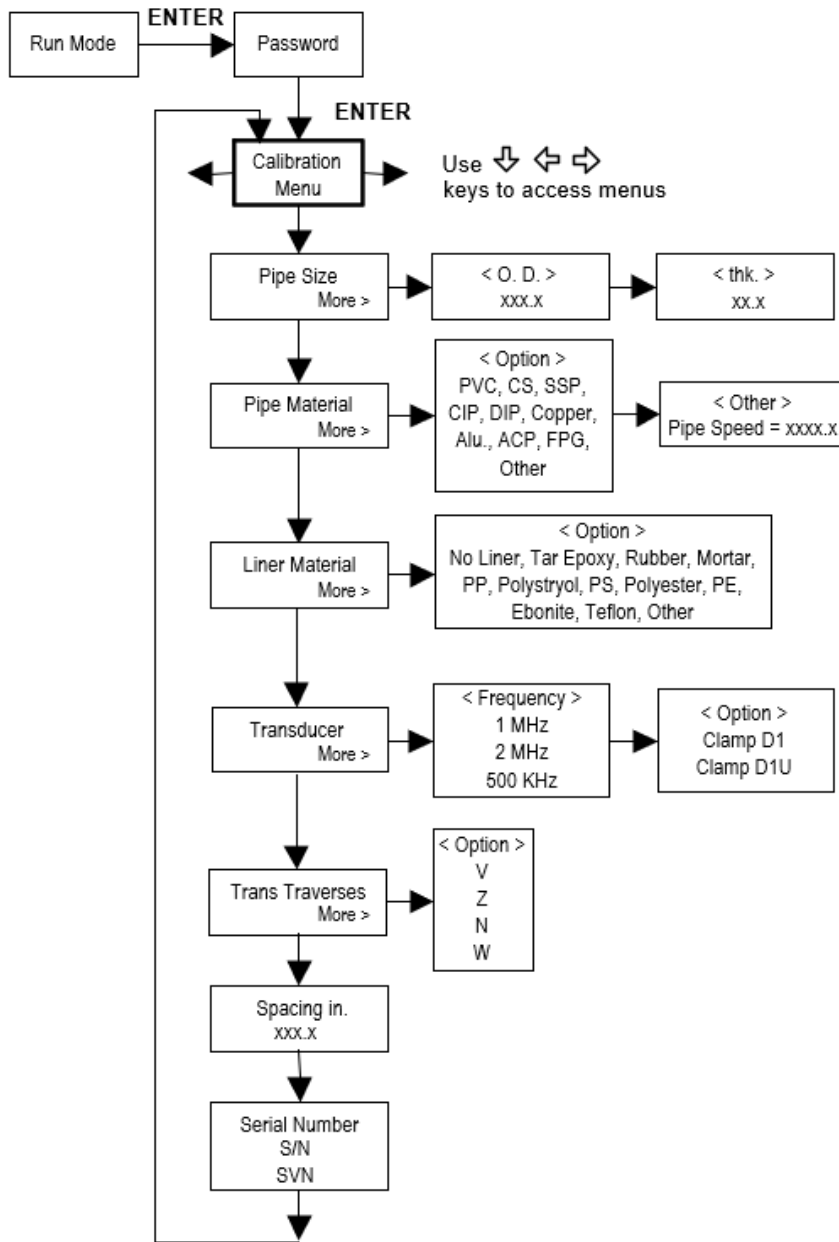

### 3.2.12 Password Menu

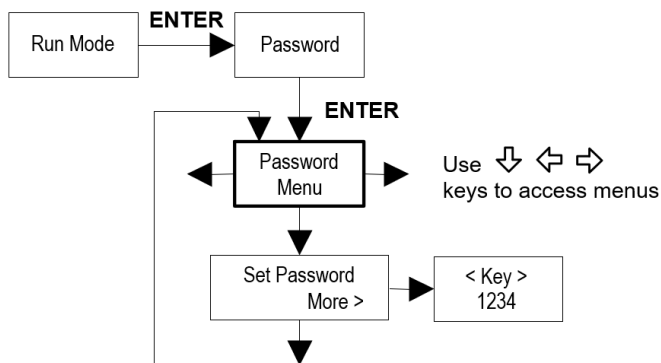

### 3.2.13 Engineer Menu

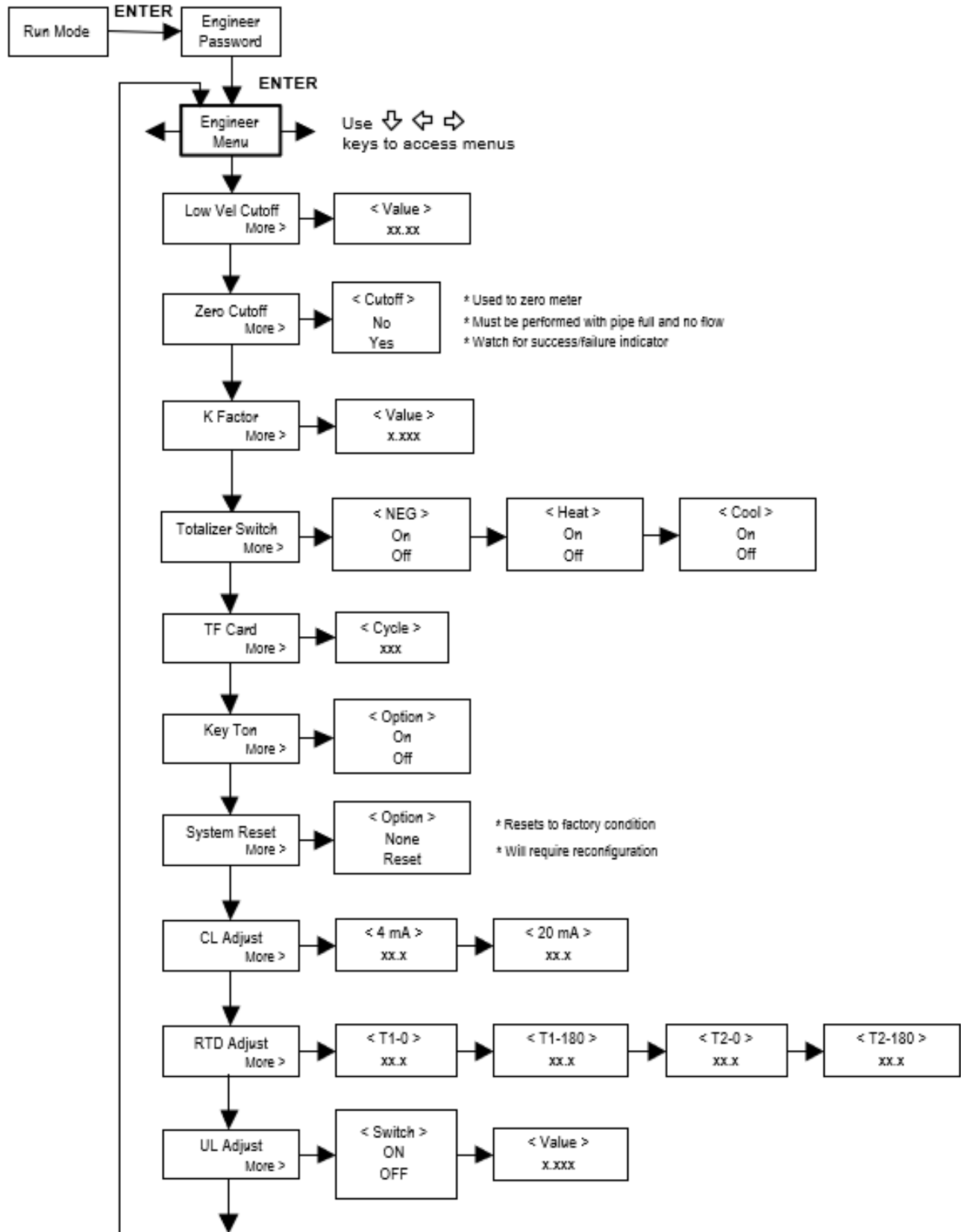

### 3.2.14 Engineer Menu 2

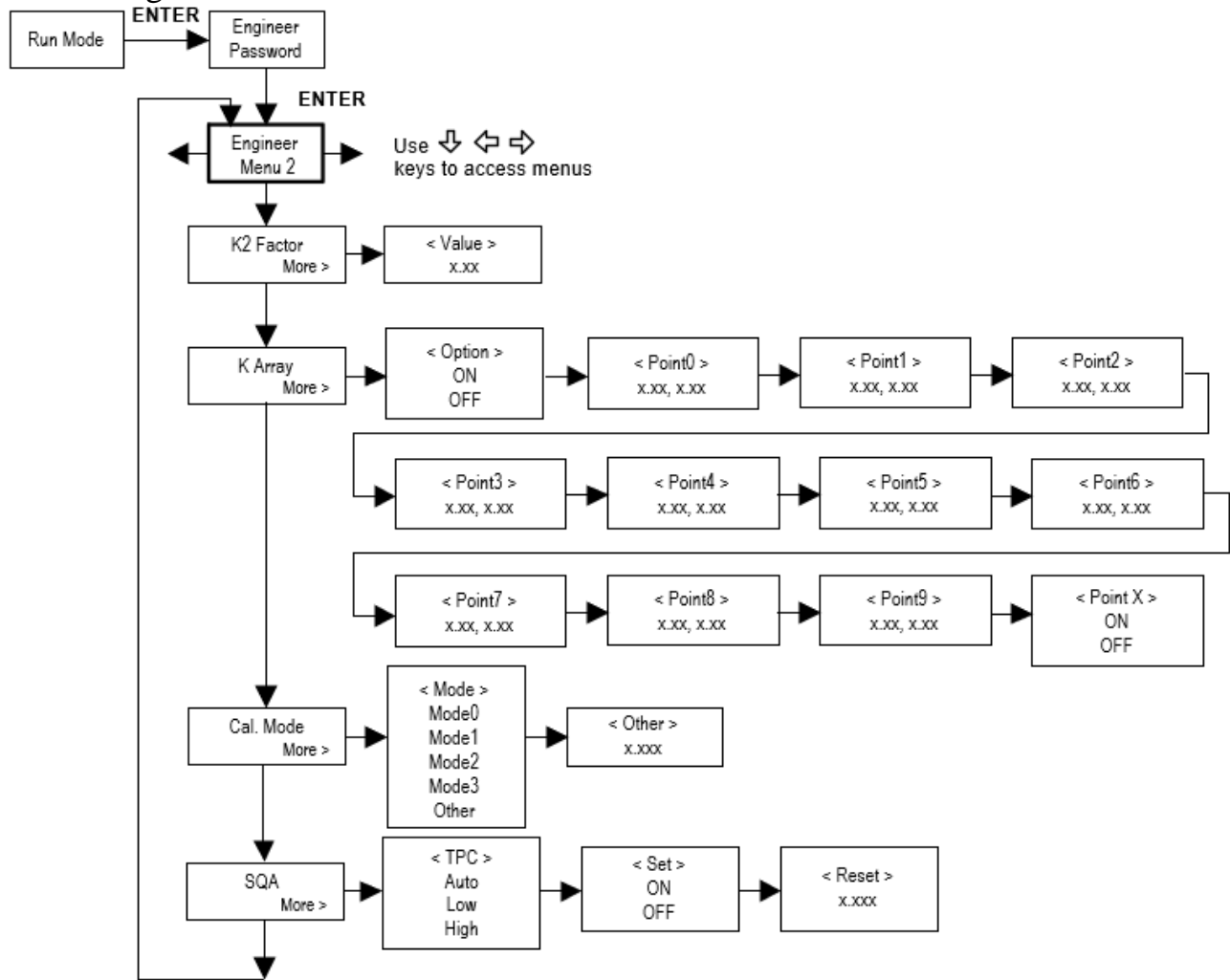

## 4. Operation Instructions

### 4.1 System Normal Identification

If the letter "\*R" displays on the screen, it indicates system normal.

If the letter "D" is displayed, it indicates the system is adjusting the signal gain prior to the measurement. It means system normal. Only when the adjustment takes too long without stopping can the system be identified as abnormal. If the letter "E" is displayed, it indicates that no signal is being detected. Check the transducer wiring connections are correct, the transducers are installed firmly, etc.

For further information, please refer to "Error Diagnosis".

### 4.2 Low Velocity Cutoff Value

The low velocity cutoff value can be found in the Engineer Menu. If the flow rate falls below the low velocity cutoff value, the flow indication is driven to zero. This function can prevent the flow meter from displaying flow as "0" after a pump was shut down, but there is still liquid movement in the pipe, which will result in cumulative error. Generally, 0.03 m/s is recommended to enter as the low velocity cutoff point.

The low velocity cutoff value has no relation to the measurement results once the velocity increases over the low velocity cutoff value.

### 4.3 Zero Point Settings

Once zero flow occurs, a zero point may be indicated on each measuring instrument, but the displayed measuring value is not equal to "0". This value indicates "Zero". To any measuring instrument, the smaller the "Zero" is, the better the quality is. Conversely, if the "Zero" is too big, that indicates the quality of the instrument is poor.

If the zero-set point is not at true zero flow, a measurement difference may occur. The smaller the physical measurement capacity is, the larger the measurement difference from the zero point will exist. Only when the zero point is reduced to a definite degree, as compared with the physical measurement capacity, can the measuring difference from the zero point be ignored.

For an ultrasonic flow meter, the measurement error from the zero point cannot be ignored under low flow conditions. It is necessary to perform a static zero set calibration to improve low flow measurement accuracy.

#### **Cutoff Zero**

In Engineer Menu – Zero Cutoff. The menu will show the “success” and back to the Run Mode Screen when you cut off the zero point successfully.

### 4.4 Scale Factor

Scale factor refers to the ratio between "actual value" and "reading value". For example, when the measurement is 2.00, and it is indicated as 1.98 on the instrument, the scale factor reading is 2/1.98. This means that the best scale factor constant is 1. However, it is difficult to keep the scale factor as "1" on the instrument especially in batch productions. The difference is called "consistency".

During operation, there still exists a possible difference in pipe parameters, etc. The "scale factor" may be necessary when used on different pipes. Thus, scale factor calibration is specially designed for calibrating the differences that result from application on different pipes. The scale factor entered must be one that results from actual flow calibration. The scale factor can be input in the Engineer Menu.

## 4.5 System Lock

System lock is intended to prevent operation error due to tampering by unauthorized personnel.

The Password Menu is for system lock. Unlock it by using the selected password only. If "lock" is displayed on the screen, then enter the correct password.

Keep the password in mind or recorded in a safe place, otherwise the instrument cannot be used.

## 4.6 Active 4 - 20 mA Current Loop Output

With a current loop output exceeding an accuracy of 0.1%, the flow meter is programmable and configurable with outputs such as 4 - 20 mA or 0 - 20 mA selected in the Output Menu. For details, please refer to the Output Menu in "Display & Menus".

In Output Menu – 4 mA Output – 4 mA, enter a 4 mA flow value. Enter the 20 mA flow value in Output Menu – 4 mA Output – 20 mA. For example, if the flow range in a specific pipe is 0 ~ 1000 m<sup>3</sup>/h, enter 0 and 1000 in Output Menu – 4 – 20 mA Output. If the flow ranges from -1000 ~ 0 ~ 2000 m<sup>3</sup>/h, configure the 20 - 4 - 20 mA output by selecting in Output Menu when flow direction is not an issue. Enter 1000 in Output Menu – 4 mA Output – 4 mA and 2000 in Output Menu – 4 mA Output – 20 mA. When flow direction is an issue, module 0 - 4 - 20 mA is available. When the flow direction displays as negative, the current output is in range of 0 - 4 mA, whereas the 4 - 20 mA is for the positive direction. The output module options are displayed in the Output Menu.

Calibrating and testing the current loop is performed in Output Menu – 4 - 20 mA Output. Complete the steps as follows:

Use < and > to switch menus. Select the 4 mA or 20 mA outputs by pressing ENTER, connecting an ammeter to test the current loop output and calculate the difference.

## 4.7 Frequency Output

The flow meter is provided with a frequency output transmitter function. The high or low frequency output displayed indicates the high or low flow rate reading. The user can reset the frequency output as well as flow rate to the user's actual requirements.

For example: if a pipe flow range is 0 ~ 5000 m<sup>3</sup>/h, the relative frequency output required is 100 ~ 1000 Hz, and the configuration is as follows:

In Output Menu – Scaled Frequency – Min Hz (lower limit frequency output flow value), input 0;

In Output Menu – Scaled Frequency – Max Hz (upper limit frequency output flow value), input 5000;

In Output Menu – Scaled Frequency – Max Frequency (frequency range), input 1000;

Typical Open Collector Transistor (OCT) Output wiring diagram as below:



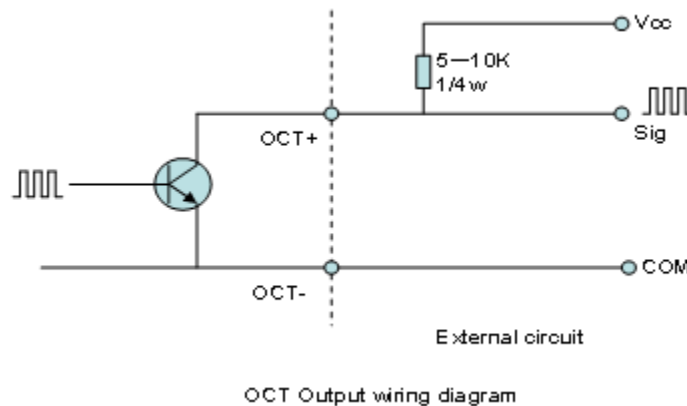

## 4.8 Totalizer Pulse Output

Each time the flow meter reaches a unit flow, it may generate a totalizer pulse output to a remote counter.

The totalizer pulse output can be transmitted through Open Collector Transistor (OCT) or a relay. Therefore, it is necessary to configure OCT and the relay accordingly. (Refer to Totalizer #1 Menu). For example, if it is necessary to transmit the positive totalizer pulse through a relay, and each pulse represents a flow of  $10 \text{ m}^3$ , the configuration is as follows:

In Units Menu – Volume Total Unit, select the totalizer flow unit " $\text{m}^3$ ";

In Totalizer #1 Menu – Pulse, select the scale factor " $\text{e.} \times 10$ ";



### Attention

Make sure to select an appropriate totalizer pulse. If the totalizer pulse is too big, the output cycle will be too long. If the totalizer is too small, the relay will operate too quickly, you may shorten the life of the relay, as well as skip some pulses. The totalizer is recommended to transmit within the range of 1 ~ 3 pulse per second.

## 4.9 Active 4 - 20 mA Analog Output Calibration



### Attention

Each flow meter has been calibrated strictly before leaving the factory. It is unnecessary to carry out this step except when the current value (detected while calibrating the current loop) displayed in Engineer Menu – CL Adjust is not identical with the actual output current value.

The hardware detect window must be activated prior to calibrating the Analog Output. The procedure is as follows: Engineer Menu – CL Adjust is for 4 - 20 mA calibration. If you need to enter the password, enter it. With no effect to next power on, this menu will close automatically as soon as the power is turned off.

Use the number keys to switch calibrate the current loop 4 mA output. Use an ammeter to measure the output of the current loop and adjust the displayed numbers at the same time. Watch the ammeter until it reads 4.00. Stop at this point, the 4 mA output has been calibrated.

Use the number keys to switch calibrate the current loop 20 mA output. The method is the same as the 4 mA calibration.

The results are automatically saved in EEPROM and won't be lost when the power is turned off.

## 4.10 SD Card Operation

### 4.10.1 Specifications

Data collection interval: any interval settings from 1 to 3600 seconds are OK according to the requirements.

Data content: date and time, flow rate, flow velocity, total flow, positive totalizer, negative totalizer.

Data storage format:

a = 2017-11-16, 16:21:12	h = + 0.000000 E+00 GJ
b = + 2.652471 E+00 m <sup>3</sup> /h	i = + 0.000000 E+00 GJ
c = + 9.380460 E-02 m/s	j = + 0.000000 E+00 C
d = + 3.520580 E+02 m <sup>3</sup>	k = + 0.000000 E+00 C
e = + 3.520580 E+02 m <sup>3</sup>	File system format: FAT16.
f = + 0.000000 E+00 m <sup>3</sup>	File type: plain text file (.TXT).
g = + 0.000000 E+00 m <sup>3</sup>	File number: maximum 512 pcs.

It can save 120 bytes of data each time. If it is set to save once every 5 seconds, the capacity of storing file in 24 hours is  $120 \times 3600 / 5 \times 24 = 2073600$  byte  $\approx 2.1$  Mbyte, therefore, 1 Gb SD card can store for days:  $1024 / 2.1 = 487.6 \approx 487$  days. When the capacity of the SD card is full, the new data will override the earliest files automatically.

### 4.10.2 Install or Remove the SD Card While the Meter is Powered On

If the operator desires to insert the SD card with power on, please turn off the power. The following operation is to be used:



**Attention:**

Do not remove the SD card from the reader while actively working with the data. Data should be saved and stored in a separate location on the PC, and then processed from that file location. Processing the data directly from the SD card file location on the PC could result in losing or destroying data if the SD card is removed while still being processed.

---

## 4.11 Serial Number

We provide the flow meter with a unique serial number to identify each flow meter for the convenience of the manufacturer and customers. The S/N, instrument types, and versions are viewable in the Engineer Menus.

## 5. Troubleshooting

### Determine Fault:

Please confirm there are no issues with First check Items above before continuing.

### Symptom: No/Low Signal Quality

Verify the meter is installed correctly and that the application has been configured correctly by using the tables below. Ensure the pipe is full and there is no air present in the pipe. Ensure there is no paint or corrosion on the pipe where the transducers are mounted. Check that the transducers are clamped securely to the pipe surface.

### Symptom: No Flow Reading When Flow is Present

Verify the signal quality is above 85. If it is not, check that the pipe is full and there is no air present in the pipe. Verify the meter is installed correctly and that the application has been configured correctly by using the tables below.

### Symptom: Erratic Output

Verify the signal quality is a consistent number above 85. Ensure that the pipe is full and there is no air present in the pipe.

### Symptom: Flow Reading When No Flow is Present

A meter zero needs to be performed. In Engineer Menu 1 (password 208.), press down until you reach Zero Cutoff. Select Yes when pipe is full and has no flow.

### Symptom: No RTD Temperature Reading

Ensure the RTDs are properly wired.

### Error Codes and Possible Solutions:

Codes	Meaning	Causes	Solutions
*R	System Normal	* System normal	
*E	Signal Not Detected	<ul style="list-style-type: none"> <li>* Signal not detected</li> <li>* Spacing is incorrect between the transducers or not enough coupling compound was applied to the face of the transducers</li> <li>* Transducers installed improperly</li> <li>* Scale is too thick</li> <li>* New pipe liner</li> </ul>	<ul style="list-style-type: none"> <li>* Attach transducer to the pipe and tighten it securely. Apply plenty of coupling compound onto transducer and pipe wall.</li> <li>* Remove any rust, scale, or loose paint from the pipe surface. Clean it with a file.</li> <li>* Check the initial parameter settings</li> <li>* Remove the scale or change the scaled pipe section.</li> <li>* Wait until liner is solidified and saturated.</li> </ul>
*D	Adjusting Gain	* Adjusting gain for normal measurement	



**Warning!**

Always remove main power before disassembling any part of the mass flow meter. Use hazardous area precautions if applicable. Static sensitive electronics - use electro-static discharge precautions.

**First Check Items:**

- Power and Wiring Correct
- Meter Range Correct for the Application
- Meter Configuration Correct

**Configuration of Application and Electronics:**

Record the following values from the Calibration Menu with the meter installed in order to determine the operating state of the flow meter:

Pipe O.D. =	
Wall Thickness =	
Pipe Material =	
Liner Material =	
Liner Thickness =	
Transducer Frequency =	
Pipe Mount Method = (Trans Traverse)	
Mounted Transducer Spacing Matches Spacing Value in Menu?	Yes or No

Record the following values from the Fluid Menu with the meter installed:

Fluid =	
---------	--

**Readings from Electronics:**

Record the following values from Run Menu with the meter installed:

System Normal Identification =	
--------------------------------	--

Record the following values from the Diagnostics Menu with the meter installed:

Signal Status UP =	
Signal Status DN =	
Signal Status Q =	
Sound Velocity Ratio =	
Transfer Times Total =	
Total Times Delta =	

**Record the following values from the Engineer Menu 1 with the meter installed:**  
(use password 208. to access)

Low Velocity Cutoff =	
Zero Cutoff =	Yes or No

**Record the following values from the Engineer Menu 2 with the meter installed:**  
(use password 209. to access)

Cal Mode =	
------------	--

Vortek Instruments, LLC  
8475 West I-25 Frontage Rd  
Longmont, CO 80504 USA  
[www.vortekinst.com](http://www.vortekinst.com)

Technical assistance may be obtained by contacting Customer Service at:  
(888) 386-7835 or (303) 682-9999 in the USA

# 6. Appendix 1 – Serial Interface Network Use and Communications Protocol

## 6.1 Overview

The flow meter is provided with a UART protocol and can also be operated by using RS-485 Modbus.

The two structures that can be used for networking are applying the analog current output method or directly applying the UART communication method of the flow meter. The first option is applicable for replacing an old meter in the previous monitoring network. The second option is used for a new monitoring network.

When the serial port communications method is directly used to implement a monitoring network system, the address identification code of the flow meter is used as a network address code. Expanded command set with [W] is used as communication protocol.

## 6.2 Connection via RS-485 to the Host Device

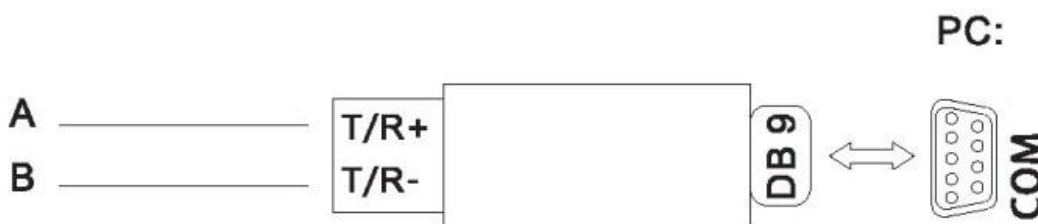

## 6.3 Modbus Communications Protocol and Use

### 6.3.1 HL Protocol

This flow meter is equipped with HL communication protocol. The host device will request the flow meter to respond after sending a “command”. Asynchronous communication baud rate is 9600 BPS in general.

Single byte data format (10 bits): One start bit, one stop bit, and eight data bits. One data character string is used to indicate the basic command, while one ENTER is used to indicate the end of the command.

Common Communication Commands:

Command	Description	Data format
RFR(cr)(lf)	Return to Transient Flow	±d.dddddddE±dd(cr) Note 1
RVV(cr)(lf)	Return to Transient Velocity	±d.dddddddE±dd(cr)
RT+(cr)(lf)	Return to POS Total	±ddddddd.dE±d(cr) Note 2
RT-(cr)(lf)	Return to NEG Total	±ddddddd.d±d(cr)
RTN(cr)(lf)	Return to NET Total	±ddddddd.d±d(cr)
RTH(cr)(lf)	Return to Total (Heat Quantity)	±ddddddd.d±d(cr)

RT-(cr)(lf)	Return to Total (Cold Quantity)	±d d d d d d d . d ± d (cr)
RER-(cr)(lf)	Return to Energy Transient Quantity	±d . d d d d d d E ± d d (cr)
RAI-(cr)(lf)	Return to Analog Input AI1 Value (temperature, pressure, and etc.)	±d . d d d d d d E ± d d (cr)
RA2-(cr)(lf)	Return to Analog Input AI2 Value (temperature, pressure, and etc.)	±d . d d d d d d E ± d d (cr)
RID-(cr)(lf)	Return to Meter Address Code	d d d d d (cr) 5-bit length
RSS-(cr)(lf)	Return to Signal Status	UP: d d . d, DN: d d . d, Q= d d (cr)
REC-(cr)(lf)	Return to Current Error Code	*R/*D/*E Note 3
RRS-(cr)(lf)	Return to Repay Status	ON/OFF (cr)
RDT-(cr)(lf)	Current time and date	yy-mm-dd, hh:mm:ss (cr)
RSN-(cr)(lf)	Return to Serial Number	d d d d d d d t (cr) Note 4
OCT-(cr)(lf)	OCT Settings	d d d d . d (cr) return to "OK" if it is set correctly
SRS-(cr)(lf)	Start Ration Control	OK (cr)
P	With check return command prefix	Note 5
W	Network command prefix of digit string address	Note 6

## Annotations:

- (cr) indicates ENTER, its ASCII code value is ODH. (lf) indicates changing a line and its ASCII code value is OAH.
- "d" indicates 0~9 digits and 0 is expressed by + 0.000000E + 00.
- "d" indicates 0~9 digits and the integral part has no decimal point.
- d d d d d d d d indicates the electronic serial number of the machine.
- Character P could be added before every basic command, it indicates the feedback data has CRC check. The check sum is obtained through binary addition, which is a binary system taking the least 8-bit binary data.

For example: Feedback information RT-(cr)(lf): +1234567E+0m3-(cr)(lf)(corresponding binary data are 2BH, 31H, 32H, 33H, 34H, 35H, 36H, 37H, 45H, 2BH, 30H, 6DH, 33H, 20H, 0DH, OAH ) sum data returned =2BH + 31H + 32H+ 33H + 34H + 35H+ 36H + 37H+45H + 2BH + 30H + 6DH + 33H + 20H = 2F7, and the least 8-bit binary is F7.

Therefore, data of command PRT-(cr)(lf) is + 1234567E + 0m3!F7-(cr)(lf), "!" as for the delimiter, the first part is the character for summation and the second part is a 1-bit check code.

- Use of W prefix: W+digit string address code+basic command, the digit string value range is 0~255, divided by 13 (ODH ENTER),10(OAH changing a line). If you want to access to the transient flow velocity of No. 123 flowmeter, you could send command W123DV (cr) (lf), the corresponding binary codes are 57H, 31H, 32H, 33H, 44H, 56H, 0DH and OAH; only the meters with the same network address and command could have data feedbacks.
- W and P commands could be combined for use, for example, W123PRT+, which means the network address it reads is the total value of No. 123 flowmeter, its feedback data are accumulated and checked.

## 6.3.2 Modbus Protocol

This Modbus-I Protocol uses RTU transmission mode. The Verification Code uses CRC-16-IBM (polynomial is  $X^{16}+X^{15}+X^2+1$ , shield character is 0xA001) which is gained by the cyclic redundancy algorithm method.

Modbus-I RTU mode uses hexadecimals to transmit data.

### 1. Modbus-I Protocol Function Code and Format

The flow meter protocol supports the following two-function codes of the Modbus:

Function Code	Performance data
0x03	Read register
0x06	Write single register

### 2. Modbus Protocol function code 0x03 usage

The host sends out the read register information frame format:

Slave Address	Operation Function Code	First Address Register	Register Number	Verify Code
1 byte	1 byte	2 bytes	2 bytes	2 bytes
0x01 ~ 0xF7	0x03	0x0000 ~ 0xFFFF	0x0000 ~ 0x7D	CRC (Verify)

The slave returns the data frame format:

Slave Address	Read Operation Function Code	Number of Data Bytes	Data Bytes	Verify Code
1 byte	1 byte	1 byte	N*x2 byte	2 bytes
0x01 ~ 0xF7	0x03	2xN*	N*x2 (Data)	CRC (Verify)

N\* = Data register number

### 3. Modbus Protocol function code 0x06 usage

The host sends a command to write a single register information frame format (function code 0x06):

Slave Address	Operation Function Code	Register Address	Register Data	Verify Code
1 byte	1 byte	2 bytes	2 bytes	2 bytes
0x01 ~ 0xF7	0x06	0x0000 ~ 0xFFFF	0x0000 ~ 0xFFFF	CRC (Verify)



The slave returns the data frame format (function code 0x06):

Slave Address	Operation Function Code	Register Address	Register Data	Verify Code
1 byte	1 byte	2 bytes	2 bytes	2 bytes
0x01 ~ 0xF7	0x06	0x0000 ~ 0xFFFF	0x0000 ~ 0xFFFF	CRC (Verify)

The range of flow meter addresses 1 to 247 (Hexadecimal: 0x01 ~ 0xF7) and can be checked in the Output Menu. For example, decimal number "11" displayed in Output Menu – Modbus means the address of the flow meter in the Modbus protocol is 0x0B.

The CRC Verify Code adopts CRC-16-IBM (polynomial is  $X^{16}+X^{15}+X^2+1$ , shield character is 0xA001) which is gained by the cyclic redundancy algorithm method. Low byte of the verify code is at the beginning while the high byte is at the end.

For example, to read the address 1 (0x01) in the RTU mode, if the instantaneous flow rate uses hour as a unit ( $m^3/h$ , namely reads 40005 and 40006 registers data), the read command is as follows:

```
0x01          0x03          0x00 0x04          0x00 0x02    0x85 0xCA
Flow Meter Address  Function Code  First Address Register Numbers    CRC Verify Code
```

Flow meter returned data is (assuming the current flow = 1.234567  $m^3/h$ )

```
0x01          0x03          0x04          0x06 0x51 0x3F 0x9E    0x3B 0x32
Flow Meter Address  Function Code  Data Bytes  Data (1.2345678)          CRC Verify Code
```

The four bytes 3F 9E 06 51 is in the IEEE754 format single precision floating point form of 1.2345678.

Pay attention to the data storage order of the above example. Using C language to explain the data, pointers can be used directly to input the required data in the corresponding variable address, the low byte will be put at the beginning, such as the above example 1.2345678 m/s, 3F 9E 06 51 data stored in order as 51 06 9E 3F.

For example, it converts the address 1 (0x01) to 2 (0x02) under the RTU mode, so to write the data of flowmeter 44100 register as 0x02, the write command is as follows:

```
0x01          0x06          0x10 0x03          0x00 0x02    0xFC 0xCB
Flow Meter Address  Function Code  Register Address  Register Number  CRC Verify Code
```

Flow meter returned data is:

```
0x01          0x06          0x10 0x03          0x00 0x02    0xFC 0xCB
Flow Meter Address  Function Code  Register Address  Register Number  CRC Verify Code
```

#### 4. Error Check

The flow meter only returns one error code 0x02 which means data first address in error.

For example, to read address 1 (0x01) of the flowmeter 40002 register data in the RTU mode, the flowmeter considers it to be invalid data, and sends the following command:

```
0x01          0x03          0x00 0x01          0x00 0x01    0xD5 0xCA
Flow Meter Address  Function Code  Register Address  Register Number  CRC Verify Code
```

Flow meter returned error code is:

0x01                      0x83              0x02                      0xC0 0xF1  
 Flow Meter Address   Error Code   Error Extended Code   CRC Verify Code

## 5. Modbus Register Address List

The flow meter Modbus Register has a read register and a write single register.

a) Read Register Address List (use 0x03 function code to read)

PDU Address	Register	Read	Write	Type	No. registers*
\$0000	40001	Flow/s - low word	32 bits real	2	
\$0001	40002	Flow/s - high word			
\$0002	40003	Flow/m - low word	32 bits real	2	
\$0003	40004	Flow/m- high word			
\$0004	40005	Flow/h - low word	32 bits real	2	
\$0005	40006	Flow/h - high word			
\$0006	40007	Velocity – low word	32 bits real	2	
\$0007	40008	Velocity – high word			
\$0008	40009	Positive total – low word	32 bits real	2	
\$0009	40010	Positive total – high word			
\$000A	40011	Positive total – exponent	16 bits int.	1	
\$000B	40012	Negative total – low word	32 bits real	2	
\$000C	40013	Negative total – high word			
\$000D	40014	Negative total – exponent	16 bits int.	1	
\$000E	40015	Net total – low word	32 bits real	2	
\$000F	40016	Net total – high word			
\$0010	40017	Net total – exponent	16 bits int.	1	

\$0011	40018	Energy flow – low word	32 bits real	2	
\$0012	40019	Energy flow – high word			
\$0013	40020	Energy total (hot) –low word	32 bits real	2	
\$0014	40021	Energy total (hot) –high word			
\$0015	40022	Energy total (hot) – exponent	16 bits int.	1	
\$0016	40023	Energy total (cold) –low word	32 bits real	2	
\$0017	40024	Energy total (cold) – exponent			
\$0018	40025	Energy total (cold) – exponent	16 bits int.	1	
\$0019	40026	Up signal int – low word	32 bits real	2	0 ~ 99.9
\$001A	40027	Up signal int – high word			
\$001B	40028	Down signal int – low word	32 bits real	2	0 ~ 99.9
\$001C	40029	Down signal int – high word			
\$001D	40030	Quality	16 bits int.	1	0 ~ 99
\$001E	40031	Error code – char 1	String	1	Refer to "Error Diagnosis" for detailed codes meanings.
\$003B	40060	Flow velocity unit –char 1,2	String	2	Only m/s right now
\$003C	40061	Flow velocity unit –char 3,4			
\$003D	40062	Flow rate unit –char 1,2	String	2	Note 1
\$003E	40063	Flow rate unit –char 3,4			
\$003F	40064	Flow total unit – char 1,2	String	1	
\$0040	40065	Energy rate unit – char1,2	String	2	Note 2
\$0041	40066	Energy rate unit – char 3,4			
\$0042	40067	Energy total unit – char 1,2	String	1	

\$0043	40068	Instrument address – low word	32 bits int.	2		
\$0044	40069	Instrument address – high word				
\$0045	40070	Serial number – char 1,2	String	4		
\$0046	40071	Serial number – char 3,4				
\$0047	40072	Serial number – char 5,6	String	4		
\$0048	40073	Serial number – char 7,8				
\$0049	40074	Analog Input AI1 Value – low word	32 bits real	2	Returned temperature value with RTD option	
\$004a	40075	Analog Input AI1 Value – high word				
\$004b	40076	Analog Input AI2 Value – low word	32 bits real	2		
\$004c	40077	Analog Input AI2 Value – high word				
\$004d	40078	4 - 20 mA Value – low word	32 bits real	2		Unit: mA
\$004e	40079	4 - 20 mA Value – high word				

## b) Single Write Register Address List (use 0x06 performance code to write)

PDU Address	Register	Description	Read/W rite	Type	No. registers*
\$1003	44100	Flow meter address (1 - 255)	R/W	16 bits int.	1
\$1004	44101	Communication Baud Rate 0 = 2400, 1 = 4800, 2 = 9600, 3 = 19200, 4 = 38400, 5 = 56000	R/W	16 bits int.	1

## Notes:

1. 16 bits int—short integer, 32 bits int – long integer, 32 bits real—floating point number, String—alphabetic string

## 7. Appendix 2 – Flow Application Data

### 7.1 Sound Velocity and Viscosity for Fluids Commonly Used

Fluid	Sound Velocity (m/s)	Viscosity
Water 20°C	1482	1.0
Water 50°C	1543	0.55
Water 75°C	1554	0.39
Water 100°C	1543	0.29
Water 125°C	1511	0.25
Water 150°C	1466	0.21
Water 175°C	1401	0.18
Water 200°C	1333	0.15
Water 225°C	1249	0.14
Water 250°C	1156	0.12
Acetone	1190	
Carbinol	1121	

Ethanol	1168	
Alcohol	1440	1.5
Glycol	1620	
Glycerin	1923	1180
Gasoline	1250	0.80
Benzene	1330	
Toluene	1170	0.69
Kerosene	1420	2.3
Petroleum	1290	
Retinal	1280	
Aviation kerosene	1298	
Peanut oil	1472	
Castor oil	1502	

### 7.2 Sound Velocity for Various Materials Commonly Used

Pipe Material	Sound Velocity (m/s)
Steel	3206
ABS	2286
Aluminum	3048
Brass	2270
Cast Iron	2460
Fiberglass-Epoxy	3430
Glass	3276
Polyethylene	1950
PVC	2540

Liner Material	Sound Velocity (m/s)
Teflon	1225
Titanium	3150
Cement	4190
Bitumen	2540
Glass	5970
Plastic	2280
Polyethylene	1600
PTFE	1450
Rubber	1600

### 7.3 Sound Velocity in Water (1 atm) at Different Temperatures

T (°C)	V (m/s)	T (°C)	V (m/s)	T (°C)	V (m/s)
0	1402.3	34	1517.7	68	1554.3
1	1407.3	35	1519.7	69	1554.5
2	1412.2	36	1521.7	70	1554.7
3	1416.9	37	1523.5	71	1554.9
4	1421.6	38	1525.3	72	1555.0
5	1426.1	39	1527.1	73	1555.0
6	1430.5	40	1528.8	74	1555.1
7	1434.8	41	1530.4	75	1555.1
8	1439.1	42	1532.0	76	1555.0
9	1443.2	43	1533.5	77	1554.9
10	1447.2	44	1534.9	78	1554.8
11	1451.1	45	1536.3	79	1554.6
12	1454.9	46	1537.7	80	1554.4
13	1458.7	47	1538.9	81	1554.2
14	1462.3	48	1540.2	82	1553.9
15	1465.8	49	1541.3	83	1553.6
16	1469.3	50	1542.5	84	1553.2
17	1472.7	51	1543.5	85	1552.8
18	1476.0	52	1544.6	86	1552.4
19	1479.1	53	1545.5	87	1552.0
20	1482.3	54	1546.4	88	1551.5
21	1485.3	55	1547.3	89	1551.0
22	1488.2	56	1548.1	90	1550.4
23	1491.1	57	1548.9	91	1549.8
24	1493.9	58	1549.6	92	1549.2
25	1496.6	59	1550.3	93	1548.5
26	1499.2	60	1550.9	94	1547.5
27	1501.8	61	1551.5	95	1547.1
28	1504.3	62	1552.0	96	1546.3
29	1506.7	63	1552.5	97	1545.6
30	1509.0	64	1553.0	98	1544.7
31	1511.3	65	1553.4	99	1543.9
32	1513.5	66	1553.7		
33	1515.7	67	1554.0		

To refer to the sound velocity of other fluids and materials, please contact the factory.